

Model 751540-J2 Rack Mounting Kit for DM7560 (Dual-housing Rack, millimeter)

1. Contents of the Package

Check that the following components are included in the package. If items are missing or if there is a problem with the appearance of the items, contact your nearest YOKOGAWA dealer.

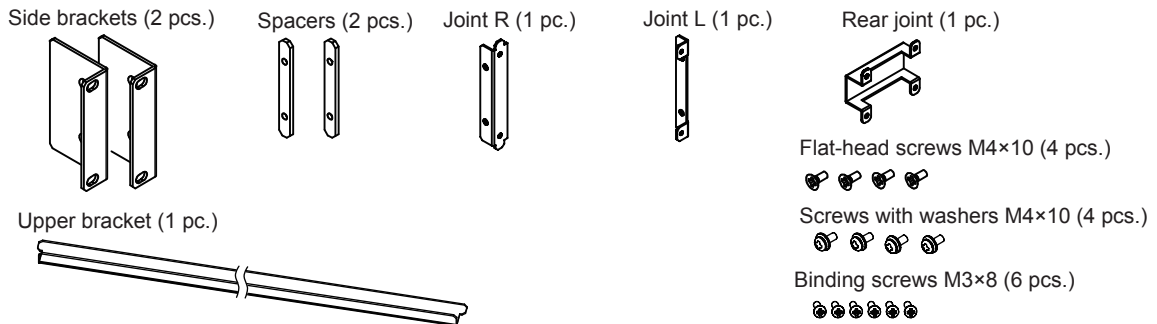

2. Removing Components for Rack Mounting

CAUTION

- When you remove the handle, be careful not to get your fingers caught between the handle and the instrument. We recommend that you use a pair of gloves.
- To use the measuring instrument without attaching the rack mount kit, be sure to put the protectors and handle back on.
Otherwise, foreign objects and the like may enter the inside of the measuring instrument through the holes for attaching the rack mount kit and may cause electric shock or malfunction.

1. Remove the protectors from the front and back of the DM7560.
2. Remove the handle. Move the handle to the position shown in the following figure, and pull the attachment areas of the handle outward to remove the handle.

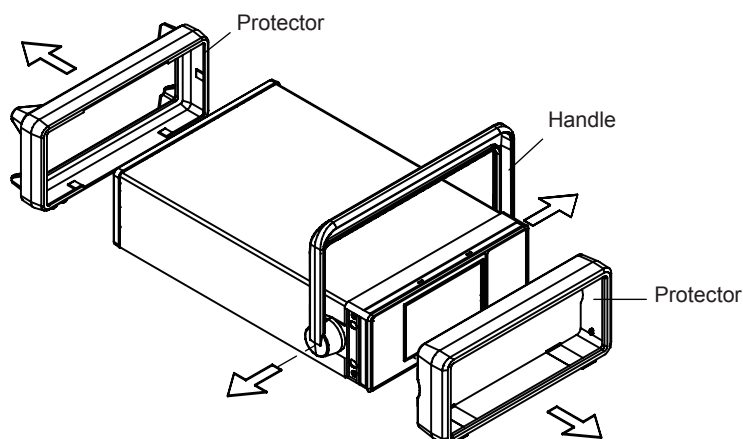

3. Attaching the Rack Mount Brackets

1. Secure the side brackets to the outer side of the two measuring instruments with flat-head screws (M4). Insert spacers between the measuring instrument and the side brackets.
Tightening torque reference: 1.4 to 1.5 N•m
2. Secure joint L and joint R to the facing sides of the two measuring instruments with screws with washers (M4). There is no problem interchanging the two joints, but be sure to attach them to the facing sides of the measuring instruments. Tightening torque reference: 1.4 to 1.5 N•m

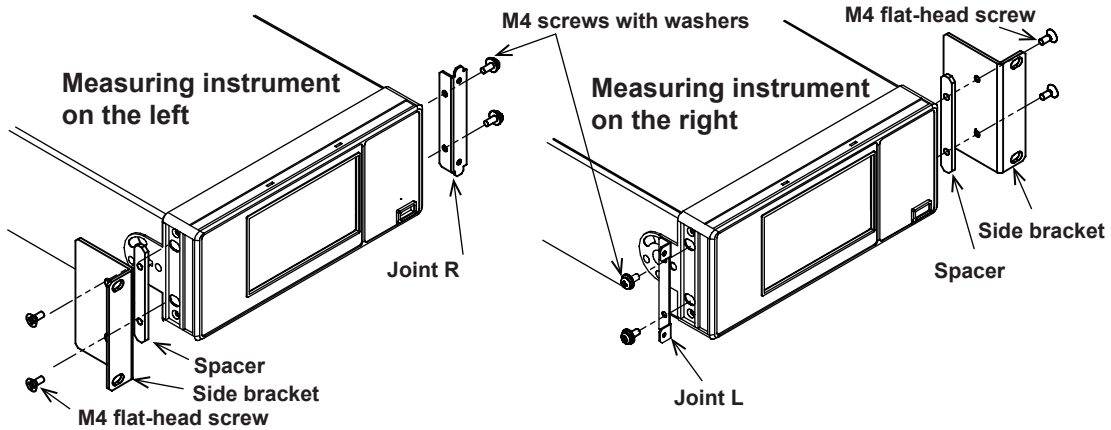

3. Place the upper bracket on top of the measuring instruments, and insert it through the corner holes of the side brackets. With joint R on the front side, align the holes of joint L and joint R, and secure them in place with binding screws (M3). Tightening torque reference: 0.6 to 0.7 N•m

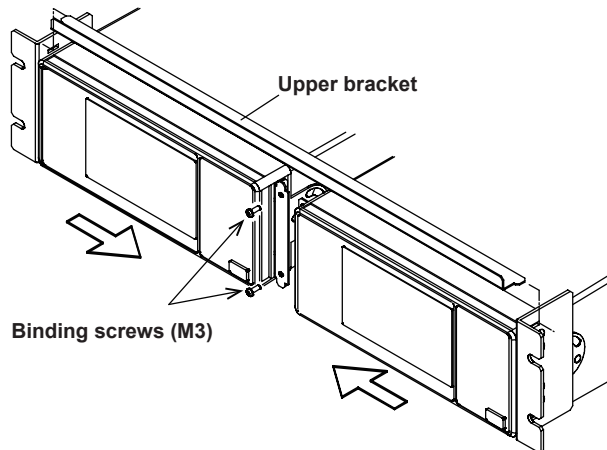

4. Fix the rear joint in place with binding screws (M3) to link the rear sides of the measuring instruments.

Tightening torque reference: 0.6 to 0.7 N•m

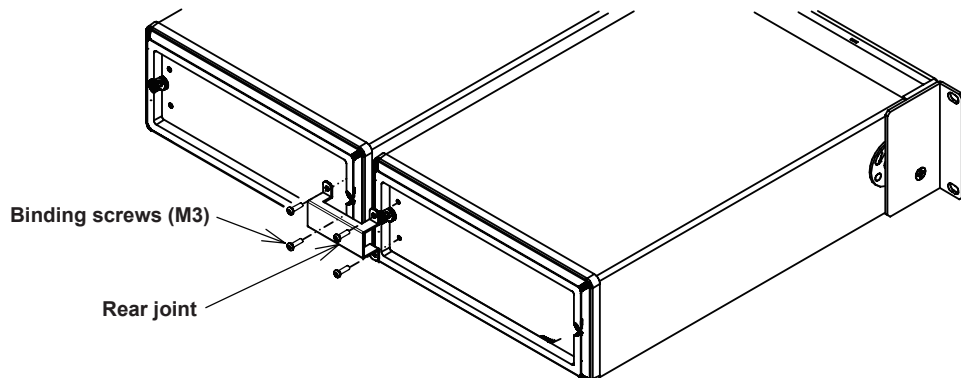

4. Mounting to a Rack

Mount the measuring instruments according to the following dimensions.

Note: Make sure to provide adequate support from the bottom of the instruments.

