

---

**User's  
Manual**

**AQ1000 OTDR  
Getting Started Guide**

---

Thank you for purchasing the AQ1000 OTDR (Optical Time Domain Reflectometer). This Getting Started Guide focuses on the handling precautions, basic operations, and specifications of the AQ1000.

To ensure correct use, please read this manual thoroughly before operation. Keep this manual in a safe place for quick reference.

The following manuals, including this one, are provided as manuals for the AQ1000.

Please read all manuals.

<b>Manual Title</b>	<b>Manual No.</b>	<b>Description</b>
AQ1000 OTDR User's Manual	IM AQ1000-01EN	A PDF file of the manual is contained in the internal memory of the AQ1000. The manual explains all the features and how to use them. For instructions on how to view the manual, see page 17.
AQ1000 OTDR Getting Started Guide	IM AQ1000-02EN	This guide. The guide explains the handling precautions and basic operations of the AQ1000 and provides a list of specifications.
AQ1000 OTDR Compliance with Radio Laws of Various Countries	IM AQ1000-03Z2	This manual explains the compliance with radio laws of various countries (for /WLN option)
AQ1000 OTDR User's Manual	IM AQ1000-92Z1	Document for China
Safety Instruction Manual	IM 00C01C01-01Z1	Safety manual (European languages)

The "EN" in the manual number is the language code.

Contact information of Yokogawa offices worldwide is provided on the following sheet.

<b>Document No.</b>	<b>Description</b>
PIM113-01Z2	List of worldwide contacts

## Notes

- The contents of this manual are subject to change without prior notice as a result of improvements to the instrument's performance and functionality. Refer to our website to view our latest manuals.
- The figures given in this manual may differ from those that actually appear on your screen.
- Every effort has been made in the preparation of this manual to ensure the accuracy of its contents. However, should you have any questions or find any errors, please contact your nearest YOKOGAWA dealer.
- Copying or reproducing all or any part of the contents of this manual without the permission of YOKOGAWA is strictly prohibited.

## Trademarks

- Microsoft, MS-DOS, Windows, Windows 10, and Windows 11 are registered trademarks or trademarks of Microsoft Corporation in the United States and/or other countries.
- Adobe, Acrobat, and PostScript are either registered trademarks or trademarks of Adobe Systems Incorporated.
- In this manual, the ® and TM symbols do not accompany their respective registered trademark or trademark names.
- Other company and product names are trademarks or registered trademarks of their respective holders.

## Updating the Firmware

It is recommended to update the firmware to the latest version to improve the features and usability of this instrument. Download the latest firmware from the YOKOGAWA website, or contact your nearest YOKOGAWA dealer for details.

## Revisions

May 2017	1st Edition	October 2017	2nd Edition	November 2024	11th Edition
November 2018	3rd Edition	September 2019	4th Edition	April 2025	12th Edition
January 2021	5th Edition	April 2021	6th Edition	September 2025	13th Edition
November 2021	7th Edition	October 2022	8th Edition		
January 2023	9th Edition	March 2023	10th Edition		

## User Registration

---

YOKOGAWA provides registered users with useful information and services. Please allow us to serve you best by completing the user registration form accessible from our website.

<https://tmi.yokogawa.com/support/>



## Contact Us

---

If you want to resolve a technical support issue or need to contact YOKOGAWA, please fill out the inquiry form on our website.

<https://tmi.yokogawa.com/contact/>



## Checking the Contents of the Package

Unpack the box, and check the contents before operating the instrument. If the wrong items have been delivered, if items are missing, or if there is a problem with the appearance of the items, contact your nearest YOKOGAWA dealer.

### AQ1000

Check that the product that you have received is the same product that you ordered. For reference, the model name, suffix code, and specifications of the products are listed below.

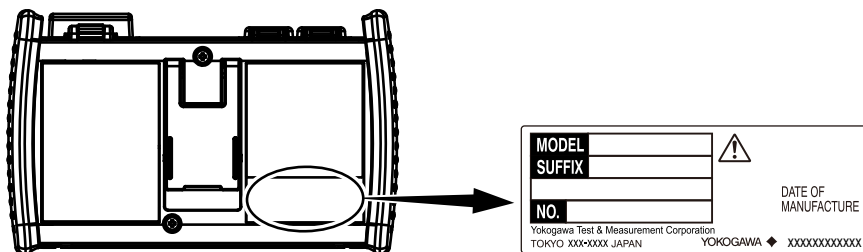

MODEL	Suffix Code <sup>1</sup>	Specifications
AQ1000		2 wavelengths 1310/1550 nm 32/30 dB (typ.)
Optical connector <sup>2</sup>	-USC	Universal adapter (SC)
	-UFC	Universal adapter (FC)
	-ASC	Universal Adapter (SC Angled-PC)
Options	/VLS	Visible light source
	/WLN <sup>3</sup>	Wireless LAN

1 For products whose suffix code contains "Z," an exclusive manual may be included. Please read it along with the standard manual.

2 The optical connector that you selected is attached to the AQ1000 OTDR port prior to shipping.

3 The regions that this product can be used in is limited by the radio laws of each country. For details, contact your nearest YOKOGAWA dealer.

### No. (Instrument number)

When contacting the dealer from which you purchased the instrument, please give them the instrument number.

## Standard Accessories

The following accessories are included. Make sure that all accessories are present and undamaged.

**USB cable**  
A1590WL

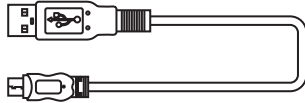

**Strap**  
B8105EP

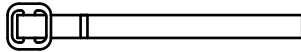

### Manuals\*

- **IM AQ1000-02EN**  
(this manual)
- **PIM113-01Z2**  
(List of contacts)
- **IM AQ1000-92Z1**
- **IM AQ00C01C01-01Z1**

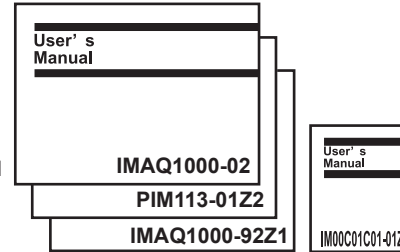

\* IM AQ1000-01EN is contained in a PDF file in the AQ1000 internal memory. A printed manual can also be purchased separately. Contact your nearest YOKOGAWA dealer to purchase a copy.

## Optional Accessories

The following optional accessories are available for purchase separately. For information about ordering accessories, contact your nearest YOKOGAWA dealer.

Item	Model/Part No.	Note
Universal adapter (SC)	735482-SCC	For the OTDR port (SC type), fixing screws (2 pcs.)
Universal adapter (FC)	735482-FCC	For the OTDR port (FC type), fixing screws (2 pcs.)
USB cable	A1590WL	1 m in length, USB type A to USB type Micro-B
Strap	B8105EP	Used by attaching to the main body

## Safety Precautions

---

This product is designed to be used by a person with specialized knowledge. The general safety precautions described herein must be observed during all phases of operation. If the product is used in a manner not specified in this manual, the protection provided by the product may be impaired. This manual is part of the product and contains important information. Store this manual in a safe place close to the instrument so that you can refer to it immediately. Keep this manual until you dispose of the instrument.

YOKOGAWA assumes no liability for the customer's failure to comply with these requirements.

### The following symbols are used on this instrument.



Warning: handle with care. Refer to the user's manual or service manual. This symbol appears on dangerous locations on the instrument which require special instructions for proper handling or use. The same symbol appears in the corresponding place in the manual to identify those instructions.



Hazard, radiation of laser apparatus



Direct current



Stand-by

### French



Avertissement : À manipuler délicatement. Toujours se reporter aux manuels d'utilisation et d'entretien. Ce symbole a été apposé aux endroits dangereux de l'instrument pour lesquels des consignes spéciales d'utilisation ou de manipulation ont été émises. Le même symbole apparaît à l'endroit correspondant du manuel pour identifier les consignes qui s'y rapportent



Danger : Appareil laser à rayonnement.



Courant direct



Veille

**Failure to comply with the precautions below could lead to injury or death or damage to the instrument.**

---

## **WARNING**

### **Use the Instrument Only for Its Intended Purpose**

This optical measuring instrument is designed to measure the optical characteristics of light sources and evaluate their performance. Do not use this instrument for anything other than as an optical measuring instrument.

### **Check the Physical Appearance**

Do not use the instrument if there is a problem with its physical appearance.

### **Battery**

- This instrument contains a battery (lithium-ion cell). The battery cannot be removed. For information on replacing the battery, contact your nearest YOKOGAWA dealer.
- Use only the supplied USB cable to charge the instrument.
- With the instrument turned off, when the battery pack is charged using the USB-AC adapter that YOKOGAWA recommends, if the battery pack is still charging after 8 hours, stop charging it immediately.
- Do not charge the instrument under direct sunlight (such as on the car dashboard or by a window), inside a vehicle under the blazing sun, near a stove or other heat source, or other hot locations.
- Your clothing may be damaged or you may be injured if you come in contact with the electrolyte in the battery due to fluid leakage or the battery exploding. Because the electrolyte may cause loss of eyesight, if it comes in contact with your eyes, immediately wash the affected area with clean water, and consult a doctor as soon as possible.
- Do not throw the instrument into fire or heat it. Such actions are dangerous as they may cause the battery to explode or the electrolyte to be sprayed about.
- For information on transporting lithium-ion batteries by air, see the requirement for each packing instruction (lithium battery instruction Section II) in the latest IATA Dangerous Goods Regulations.

### **Laser Beam**

Do not look directly or indirectly into the laser beam or at a specular reflection of the beam without protective equipment. Do not aim the laser beam at the eye. Doing so may cause blindness or damage to your eyes. Attach the cover to the optical connector when it is not in use. Be sure to turn off this instrument before you clean it.

### **Connecting Optical Fiber Cables**

Use optical fiber cables that are compatible with the universal adapter (the universal adapter is specified with a suffix code).

### **Applying Light to the Optical Connector**

Do not apply light that is  $-5$  dBm or greater to the optical connector of the OTDR port. Doing so can damage the instrument.

### **Do Not Operate in an Explosive Atmosphere**

Do not use this instrument in the presence of flammable gases or vapors. Doing so is extremely dangerous.

### **Do Not Remove Covers or Disassemble or Alter the Instrument**

Only qualified YOKOGAWA personnel may remove the covers and disassemble or alter the instrument.

### **Installation Location**

Using a stand in an unstable location is extremely dangerous. If you are installing the instrument using a stand, install in a stable location.

---

---

## **CAUTION**

### **Operating Environment Limitations**

This product is a Class A (for industrial environments) product. Operation of this product in a residential area may cause radio interference in which case the user will be required to correct the interference.

---

## AVERTISSEMENT

### Utiliser l'instrument aux seules fins prévues

Cet instrument de mesure optique est prévu pour mesurer les caractéristiques optiques des sources lumineuses et évaluer leur performance. Ne pas utiliser cet instrument à d'autres fins que celles de mesure optique.

### Inspecter l'apparence physique

Ne pas utiliser l'instrument si son intégrité physique semble être compromise.

### Batterie

- Cet instrument contient une batterie (cellule au lithium-ion). La batterie ne peut être retirée. Pour plus d'informations sur le remplacement de la batterie, contacter votre fournisseur YOKOGAWA le plus proche.
- Utiliser uniquement le câble USB fourni pour charger l'instrument.
- Avec l'instrument hors tension, lorsque le pack de batteries est chargé à l'aide de l'adaptateur USB-CA recommandé par YOKOGAWA, si le pack de batteries est encore en charge après 8 heures, arrêter le chargement immédiatement.
- Ne pas charger l'instrument en plein soleil (par exemple sur le tableau de bord de la voiture ou sur le rebord d'une fenêtre), dans un véhicule stationné sous un soleil de plomb, à proximité d'une gazinière ou de toute autre source de chaleur ou dans tout autre endroit chaud.
- Tout contact avec l'électrolyte échappé en raison d'une fuite ou d'une explosion du pack de batteries peut endommager les vêtements ou causer des blessures. L'électrolyte peut entraîner la cécité, par conséquent, en cas de contact avec les yeux, rincer immédiatement à l'eau et consulter un médecin dans les plus brefs délais.
- Tenir le pack de batteries éloigné de toute source de chaleur et des flammes pour éviter le risque d'explosion du pack de batteries ou de déversement d'électrolyte.
- Pour toute information sur le transport aérien des batteries au lithium-ion, consulter les exigences énoncées dans le Règlement de l'IATA sur le transport des marchandises dangereuses (instruction sur les batteries au lithium).

### **Faisceau laser**

Ne pas fixer directement ou indirectement le faisceau laser, ni la réflexion spéculaire du faisceau en l'absence d'équipement de protection. Ne pas orienter le faisceau laser en direction des yeux. Le faisceau laser peut entraîner la cécité ou causer des lésions oculaires. Recouvrir le connecteur optique à l'aide du cache pendant les périodes de non-utilisation. Mettre l'AQ1000 HORS tension pendant son nettoyage.

### **Connexion des câbles à fibre optique**

Utiliser des connecteurs de câbles à fibre optique conformes à l'adaptateur universel fourni (adaptateur universel indiqué par le suffixe).

### **Envoyer un signal au connecteur optique**

Ne pas appliquer un signal de -5 dBm ou plus au connecteur optique du port OTDR. Cela pourrait endommager l'instrument.

### **Ne pas utiliser dans un environnement explosif**

Ne pas utiliser l'instrument en présence de gaz ou de vapeurs inflammables. Cela pourrait être extrêmement dangereux.

### **Ne pas retirer le capot, ni démonter ou modifier l'instrument**

Seul le personnel YOKOGAWA qualifié est habilité à retirer le capot et à démonter ou modifier l'instrument. Certains composants à l'intérieur de l'instrument sont à haute tension et par conséquent, représentent un danger.

### **Position d'installation**

Lorsque vous manipulez les pieds ou le support escamotable, soutenez toujours l'instrument fermement. Prendre les précautions suivantes.

---

---

## **ATTENTION**

### **Limitations relatives à l'environnement opérationnel**

Ce produit est un produit de classe A (pour environnements industriels). L'utilisation de ce produit dans un zone résidentielle peut entraîner une interférence radio que l'utilisateur sera tenu de rectifier.

---

## Safety Precautions for Laser Products

This instrument uses a laser light source. This instrument is a Class 1 laser product and Class 3R laser product as defined by IEC 60825-1:2014 Safety of Laser Products—Part1: Equipment Classification and Requirements. In addition, this instrument complies with 21 CFR 1040.10 and 1040.11 except for conformance with IEC 60825-1 Ed.3., as described in Laser Notice No. 56, dated May 8, 2019.

**SI L'OPTION VLS EST DISPONIBLE**

**RAYONNEMENT LASER VISIBLE**  
**ÉVITER L'EXPOSITION DIRECTE DES YEUX**  
**PRODUIT LASER DE CLASSE 3R**  
 (EN 60825-1:2014+A11:2021)  
 (IEC 60825-1:2014)  
**PUISSANCE MAXIMALE 5 mW**  
**LONGUEUR D'ONDE 650±20 nm**  
**DURÉE D'IMPULSION À ONDES CONTINUES (CW)**

**CLASS 1 LASER PRODUCT**  
 1类激光产品  
 (EN 60825-1:2014+A11:2021)  
 (IEC 60825-1:2014, GB/T 7247.1-2024)

**IF VLS OPTION IS AVAILABLE**  
 安装了VLS选项时

**VISIBLE LASER RADIATION** 可见激光辐射  
**AVOID DIRECT EYE EXPOSURE** 避免眼睛受到直接照射  
**CLASS 3R LASER PRODUCT** 3R类激光产品  
 (EN 60825-1:2014+A11:2021)  
 (IEC 60825-1:2014, GB/T 7247.1-2024)  
**MAX OUTPUT 5mW**  
**WAVELENGTH 650±20 nm**  
**PULSE DURATION CW**

Complies with 21 CFR 1040.10 and 1040.11 except for conformance with IEC 60825-1 Ed. 3., as described in Laser Notice No. 56, dated May 8, 2019.  
 4-9-8 Myojin-cho, Hachioji-shi, Tokyo 192-8566, Japan

**Laser Class 1 Label**  
 Avoid direct eye exposure.

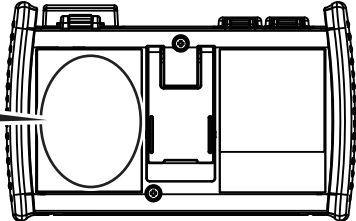

**AQ1000**

**Laser Class 3R Label**  
 Avoid direct eye exposure.

### Note

Laser classes differ depending on the standard number and the year of the standard.

Take safety measures according to the laser class corresponding to the standard of the country or region that the instrument will be used in.

## OTDR Port

Model	Class†	Center Wavelength	Maximum Output Power††	Mode Field Diameter	Beam Divergence Angle
AQ1000	1	1310 nm/1550 nm	CW: 50 mW@1310 nm/1550 nm Pulse: 200 mW@1310 nm/1550 nm Pulse width: 20 μs@1310 nm/1550 nm, Duty: ≤ 3.0%	9 μm	11.5°

† Class 1: EN 60825-1:2014+A11:2021, IEC 60825-1:2014, GB/T 7247.1-2024

†† Under single fault conditions.

## VLS Port†

Model	Class††	Center Wavelength	Maximum Output Power††	Mode Field Diameter	Beam Divergence Angle
AQ1000	3R	650 nm	CW: 5 mW	9 μm	11.5°

† Applicable to models with the /VLS option.

†† Under single fault conditions.

††† EN 60825-1:2014+A11:2021, IEC 60825-1:2014, GB/T 7247.1-2024

## Regulations and Sales in Each Country or Region

### Waste Electrical and Electronic Equipment (WEEE)



(EU WEEE Directive valid only in the EEA\* and UK WEEE Regulation in the UK)

This product complies with the WEEE marking requirement. This marking indicates that you must not discard this electrical/ electronic product in domestic household waste. When disposing of products in the EEA or UK, contact your local Yokogawa office in the EEA or UK respectively.

\* EEA: European Economic Area

## Batteries and Waste batteries



(EU Battery Directive/Regulation valid only in the EEA and UK Battery Regulation in the UK)

Batteries are included in this product. This marking indicates they shall be sorted out and collected as ordained in the EU battery directive/Regulation and UK battery Regulation.

Battery type:

1. Lithium battery

You cannot replace batteries by yourself. When you need to replace batteries, contact your local Yokogawa office in the EEA or UK respectively.

2. Lithium-ion battery

You cannot replace batteries by yourself. When you need to replace batteries, contact your local Yokogawa office in the EEA or UK respectively.

## Recycle Mark



Li-ion

Do not dispose together with normal garbage. To protect the environment, please dispose according to the recycling ordinances in your area.

## Authorized Representative in the EEA

Yokogawa Europe B.V. is the authorized representative of Yokogawa Test & Measurement Corporation for this product in the EEA. To contact Yokogawa Europe B.V., see the separate list of worldwide contacts, PIM 113-01Z2.

# Compliance with Radio Laws of Various Countries

## Chinese Radio Law

使用微功率短距离无线电发射设备应当符合国家无线电管理有关规定

1. 符合“微功率短距离无线电发射设备目录和技术要求”的具体条款和使用场景，采用的天线类型和性能，控制、调整及开关等使用方法；
2. 不得擅自改变使用场景或使用条件、扩大发射频率范围、加大发射功率（包括额外加装射频功率放大器），不得擅自更改发射天线；
3. 不得对其他合法的无线电台（站）产生有害干扰，也不得提出免受有害干扰保护；
4. 应当承受辐射射频能量的工业、科学及医疗（ISM）应用设备的干扰或其他合法的无线电台（站）干扰；
5. 如对其他合法的无线电台（站）产生有害干扰时，应立即停止使用，并采取措施消除干扰后方可继续使用；
6. 在航空器内和依据法律法规、国家有关规定、标准划设的射电天文台、气象雷达站、卫星地球站（含测控、测距、接收、导航站）等军民用无线电台（站）、机场等的电磁环境保护区域内使用微功率设备，应当遵守电磁环境保护及相关行业主管部门的规定；
7. 禁止在以机场跑道中心点为圆心、半径 5000 米的区域内使用各类模型遥控器；
8. 微功率设备使用时温度和电压的环境条件。

## Korean Radio Law

- 해당 무선설비는 전파혼신 가능성이 있으므로 인명안전과 관련된 서비스는 할 수 없습니다
- A 급 기기 ( 업무용 방송통신기자재 )  
이 기기는 업무용 ( A 급 ) 전자파적합기기로서 판매자또는 사용자는 이 점을 주의하시기 바라며 , 가정외의 지역에서 사용하는 것을 목적으로 합니다 .

## Thai Radio Law

This telecommunication equipment is in compliance with NBTC requirements.



## EU Radio Law

When AQ1000 OTDR contains the optional code of /WLN, AQ1000 OTDR is built in compliance with requirements of RE Directive:

We, Yokogawa Test & Measurement Corporation hereby declare that this equipment, model AQ1000 OTDR is in compliance with the essential requirements and other relevant provisions of Directive 1999/5/EC.

The EU declaration of conformity for RE Directive for this product can be found at

< <http://tmi.yokogawa.com/products/optical-measuring-instruments/optical-time-domain-reflectometer/aq1000-otdr-optical-time-domain-reflectometer/> >

## Brazil Radio Law

Este equipamento opera em caráter secundário, isto é, não tem direito a proteção contra interferência prejudicial, mesmo de estações do mesmo tipo e não pode causar interferência a sistemas operando em caráter primário.

Para consultas, visite: [www.anatel.gov.br](http://www.anatel.gov.br)

## Conventions Used in This Guide

---

### Notes

The notes and cautions in this guide are categorized using the following symbols.



*Improper handling or use can lead to injury to the user or damage to the instrument.* This symbol appears on the instrument to indicate that the user must refer to the user's manual for special instructions. The same symbol appears in the corresponding place in the user's manual to identify those instructions. In the manual, the symbol is used in conjunction with the word "WARNING" or "CAUTION."

### **WARNING**

Calls attention to actions or conditions that could cause serious or fatal injury to the user, and precautions that can be taken to prevent such occurrences.

### **CAUTION**

Calls attention to actions or conditions that could cause light injury to the user or damage to the instrument or user's data, and precautions that can be taken to prevent such occurrences.

### French



Une manipulation ou une utilisation incorrectes risquent de blesser l'utilisateur ou d'endommager l'instrument. Ce symbole apparaît sur l'instrument pour indiquer à l'utilisateur qu'il doit se reporter au manuel de l'utilisateur afin d'y lire les instructions spécifiques correspondantes. Ce même symbole apparaît à la section correspondante du manuel de l'utilisateur pour signaler lesdites instructions. Dans le manuel de l'utilisateur, ce symbole est accompagné des termes AVERTISSEMENT et ATTENTION.

### **AVERTISSEMENT**

Attire l'attention sur des gestes ou des conditions susceptibles de provoquer des blessures graves (voire mortelles), et sur les précautions de sécurité pouvant prévenir de tels accidents.

### **ATTENTION**

Attire l'attention sur des gestes ou des conditions susceptibles de provoquer des blessures légères ou d'endommager l'instrument ou les données de l'utilisateur, et sur les précautions de sécurité susceptibles de prévenir de tels accidents.

### Note

Calls attention to information that is important for the proper operation of the instrument.

## How to View the User's Manual

The following PDF file is stored in the USERS\_MANUAL folder in the AQ1000's internal memory.

File Name	Manual Title	Manual No.
Features & Operation Manual_*.pdf	AQ1000 OTDR User's Manual	IM AQ1000-01EN

\*\* is used to indicate the revision number.

To view the PDF file above, you need Adobe Reader 5.0 or later.

Follow the procedure below to open the PDF file.

1. Turn on the instrument.
2. Connect the type B (editionMicro-B) USB port on the top panel of the instrument to the type A USB port of the PC with the supplied USB cable. For a description of the top panel, see "Component Names and Functions." If the instrument is connected to the PC for the first time as a mass storage device, a USB driver is automatically installed in the PC.

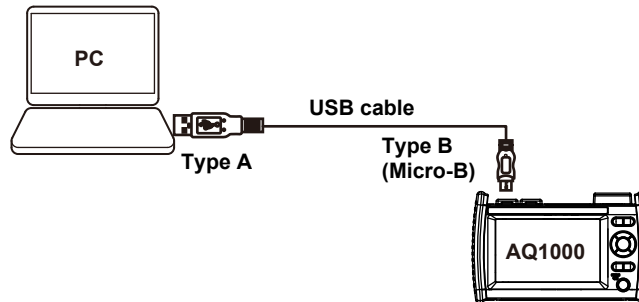

3. On your PC, start Explorer or other browser. The folder in the AQ1000's internal memory will be displayed.
4. Open the /USER/DATA/USERS\_MANUAL folder. The following PDF file will be displayed.
5. Open the PDF file. The user's manual appears on the computer screen.

# Contents

---

User Registration .....	3	<b>Setting the Language and Date and Time</b> .....	40
Contact Us .....	3	Selecting the Language to Display.....	40
Checking the Contents of the Package.....	4	Selecting the Date and Time to Display .....	41
Safety Precautions .....	6	<b>Averaged Measurement</b> .....	42
Regulations and Sales in Each Country or Region .....	12	Performing Averaged Measurements.....	42
Compliance with Radio Laws of Various Countries.....	14	Displaying the Event Analysis Results .....	43
Conventions Used in This Guide.....	16	<b>Analysis using the Emulation Software</b> .....	45
How to View the User's Manual .....	17	<b>Specifications</b> .....	46
<b>Component Names and Functions</b> .....	19	Optical Pulse Measurement Section (OTDR) .....	46
<b>Making Preparations for Measurements</b> .....	22	Power Checker Section.....	47
Handling Precautions .....	22	Stabilized Light Source Section .....	47
⚠ Connecting the USB-AC Adapter and Charging the Instrument 23	23	Visible Light Source (/VLS option) .....	47
Attaching the Strap.....	26	Common Specifications .....	48
⚠ Connecting the Optical Fiber Cable .....	27	OTDR Function .....	48
Turning the Power On .....	30	General Specifications .....	49
<b>Screen Operations</b> .....	31	External Dimensions .....	51
Screen Immediately after Power-on (Startup Window).....	31		
MENU Screen .....	35		
Operating the Arrow Keys and CURSOR/ZOOM Key.....	36		
Operating the Touch Panel.....	38		
Entering Text .....	39		

# Component Names and Functions

## Front Panel

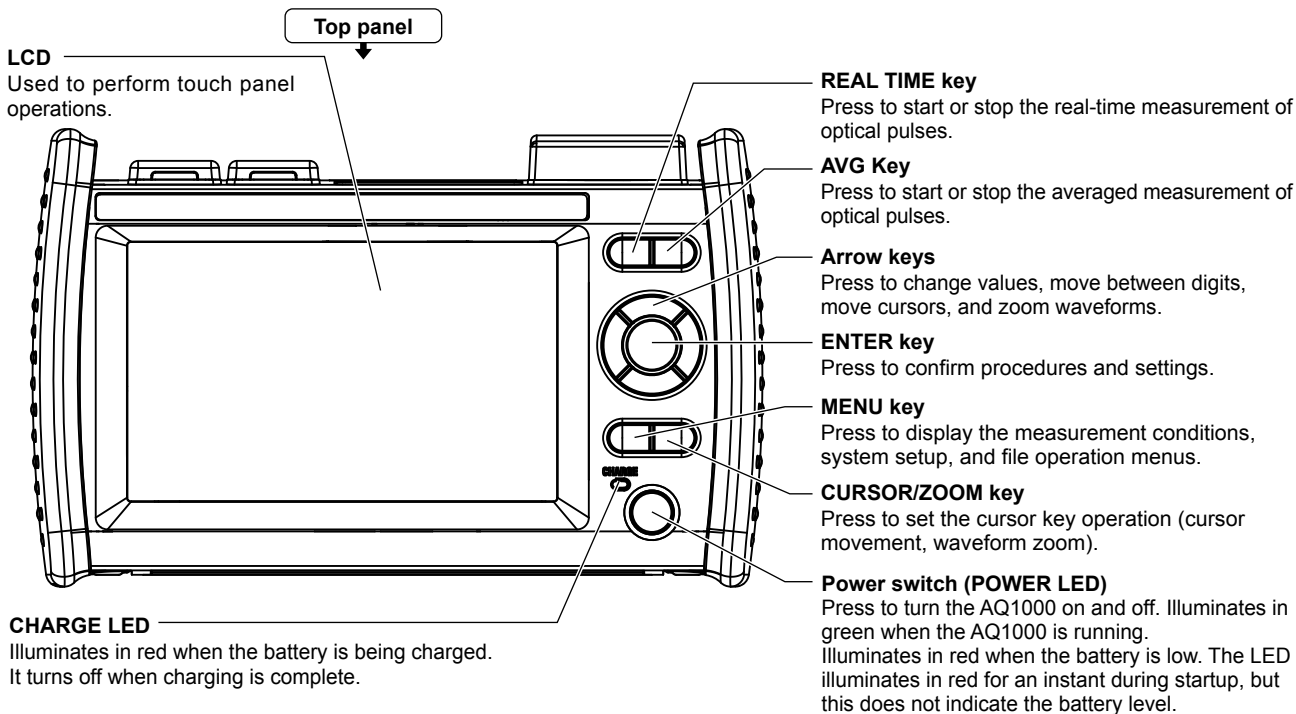

Top Panel

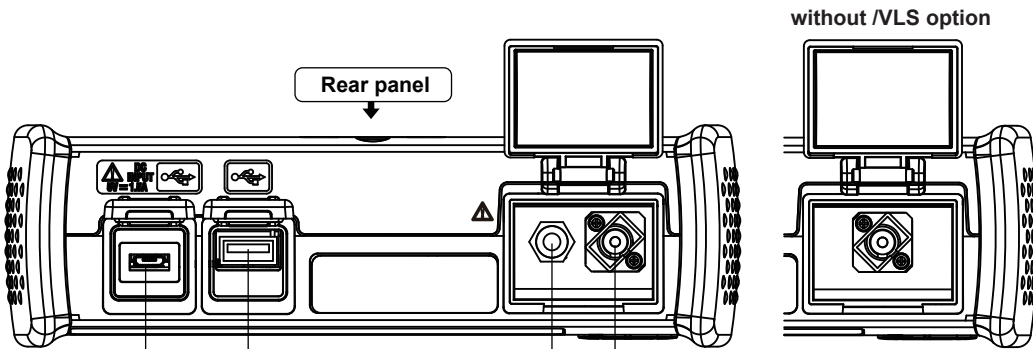

**Type B (Micro-B) USB port**

Used to charge the AQ1000 with the USB-AC adapter and to access the AQ1000 internal memory (USB mass storage) from a PC. Note that the charging function and USB mass storage function cannot be used simultaneously.

**Type A USB port**

Used to connect a USB memory device  
Note that USB keyboards cannot be used.

**OTDR port**

Used for OTDR measurement, power checker measurement, and light source output.

**VLS port (/VLS option)**

Used for VLS output.

## Rear and Side Panels

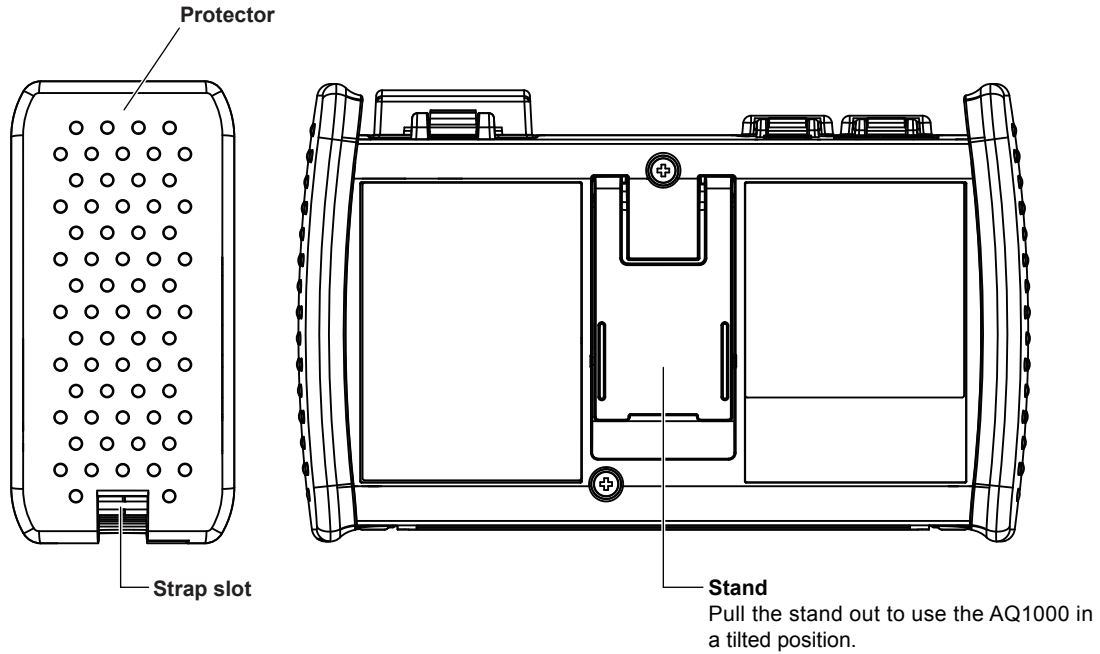

# Making Preparations for Measurements

## Handling Precautions

### Safety Precautions

If you are using this instrument for the first time, make sure to thoroughly read “Safety Precautions,” on pages 6 to 10.

#### **Do Not Remove the Case**

Do not remove the case from the instrument. Doing so is extremely dangerous. For internal inspection, adjustment and battery replacement, contact your nearest YOKOGAWA dealer.

#### **Unplug If Abnormal Behavior Occurs**

If you notice smoke or unusual odors coming from the instrument, immediately turn off the power, unplug the USB-AC adapter, and contact your nearest YOKOGAWA dealer.

#### **Handle the USB-AC Adapter and USB Cable Properly**

Do not place objects on top of the USB-AC adapter or USB cable, and keep them away from heat sources.

### General Handling Precautions

#### **Do Not Place Objects on Top of the Instrument**

Never place objects such as other instruments or objects that contain water on top of the instrument. Doing so may damage the instrument.

#### **Do Not Subject the OTDR Port or VLS Port to Mechanical Shock**

If the optical connectors or universal adapters are subjected to mechanical shock, they may be damaged. The instrument may not perform measurements correctly due to damage or deformation that is not visible to the naked eye.

#### **Do Not Scratch the LCD**

Because the LCD can be easily scratched, do not allow any sharp objects near it. Also, do not apply vibration or shock to it. Do not apply strong shock to the LCD or place objects on top of it.

#### **When Carrying the Instrument**

First, remove all cables including the USB cable and optical fiber cable. When carrying the instrument, grasp the protector or the attached strap firmly.

## Connecting the USB-AC Adapter and Charging the Instrument



### WARNING

- Only use the USB-AC adapter that YOKOGAWA recommends.
- Use the USB-AC adapter after confirming that the rated supply voltage matches the voltage of the power supply.
- Use only the supplied USB cable.
- Before connecting a USB cable to the Type B (Micro-B) USB port, make sure to check the orientation of the connector. Forcing the USB cable connector into the USB port with incorrect orientation may cause the connector to break.

### French



### AVERTISSEMENT

- Utiliser l'adaptateur USB-CA recommandé par YOKOGAWA.
- Utiliser l'adaptateur USB-CA après confirmation que la tension d'alimentation nominal correspond à la tension d'alimentation.
- Utiliser uniquement le câble USB fourni.
- Avant de connecter un câble USB au port USB de Type B (Micro-B), vérifier l'orientation du connecteur. Brancher le connecteur du câble USB de force avec une mauvaise orientation risquerait de casser le connecteur.

## Making Preparations for Measurements

1. Connect one end of the supplied USB cable to the type B (Micro-B) USB port of the instrument.
2. Connect the other end of the cable to the type A USB port of the USB-AC adapter.
3. Connect the USB-AC adapter's power plug to an outlet. The instrument's CHARGE indicator turns on red.

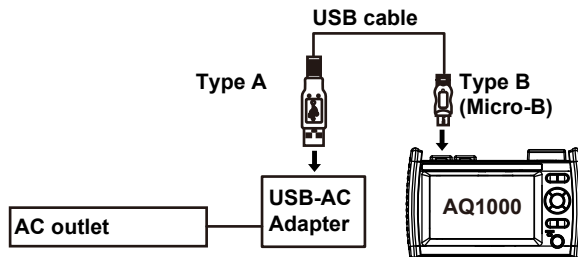

---

### Note

- If the instrument's connector cover comes off, bend the cover axle and reattach it.
  - For details on the USB-AC adapter, contact your nearest YOKOGAWA dealer.
  - The battery cannot be charged by connecting to a PC (YOKOGAWA provides no guarantee). Be sure to connect the USB-AC adapter to charge the battery.
-

## Charging the Instrument

- When the instrument's battery is low, a warning message will appear.
- When the battery is low, connect the USB-AC adapter to an electrical outlet, and charge the instrument. For the estimated battery level, check the battery level indicator at the top of the screen.

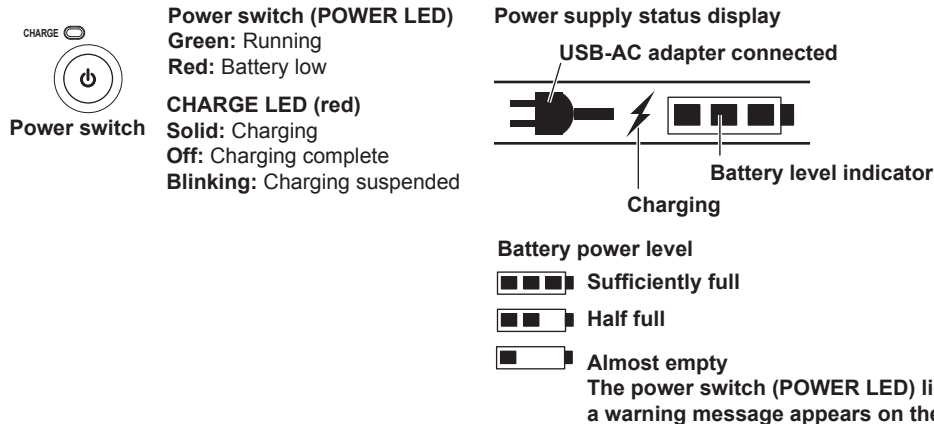

- Charging takes about 5 hours with the power turned off. If the instrument is charged with the power turned on, it may take longer than 15 hours, but charging will be suspended after about 15 hours by the protection circuit. If battery charging does not complete within 8 hours with the power turned off, stop immediately. The battery in the instrument may be malfunctioning. Contact your nearest YOKOGAWA dealer.

### Note

#### Over Discharge and Long Periods of Storage

- If you do not use the instrument for an extended period of time, the battery in the instrument may become over discharged. This shortens the service life of the battery. To prevent over discharging, charge the instrument once a month.
- Charge the instrument prior to its first use or if it has not been used for an extended period of time.

## Attaching the Strap

Attach the strap to the strap slot on each side of the instrument.

As shown in the figure, pass the strap through the strap slot on the side panel and through the buckle.

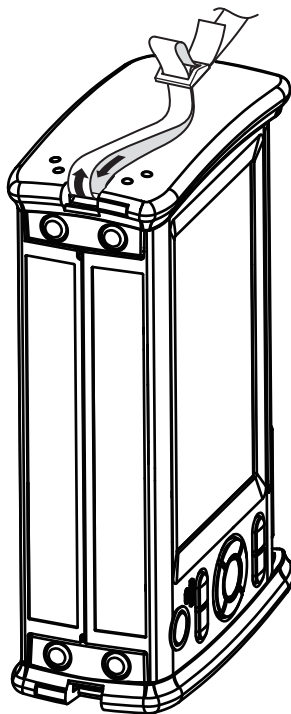

## Connecting the Optical Fiber Cable



### WARNING

- During measurement, light is transmitted from the optical ports. Do not disconnect the connected optical fiber cable. Visual impairment may occur if the light enters the eye.
- Close the optical port covers if you are not connecting optical fiber cables to them. Visual impairment may occur if light that is mistakenly emitted from the optical ports enters the eye.



### CAUTION

- Insert the optical fiber cable connector slowly and straight into the optical port. If you shake the connector to the left and right or force it into the port, the optical connector or optical port may be damaged.
- If you use optical connectors that do not meet the specifications, the instrument's optical ports may be damaged. Use optical connectors that are approved or used by national or local telecom carriers and providers in your area.
- Use optical fiber cable connectors that match the universal adapters or connector adapters that are attached to the instrument's optical ports.

#### **Using SC Angled Physical Contact Connectors (Suffix code -ASC)**

- The SC angled physical contact connector's ferrule tip is angle-polished. Use optical fiber cables whose connectors are of the same type. Using a different type of connector may damage the connector end face.
- Only use SC-type (735482-SCC) universal adapters on OTDR port. Otherwise, the instrument optical ports or the optical fiber cable connectors may be damaged.

### French



#### **AVERTISSEMENT**

- Lorsque l'AQ1000 génère de la lumière, la lumière est émise à travers les ports de source lumineuse. Ne pas débrancher les câbles de fibre optique connectés. Des lésions oculaires peuvent être causées si le faisceau lumineux pénètre l'œil.
- Masquer les orifices des ports optiques sur lesquels aucun câble à fibres optiques n'est branché. Une déficience visuelle peut se produire si la lumière émise par erreur du mauvais port optique pénètre dans l'œil.



#### **ATTENTION**

- Insérer les connecteurs de câbles à fibre optique délicatement et sans les incliner dans les ports optiques. Éviter de faire pression sur le connecteur ou de forcer pour l'insérer dans le port, car cela pourrait endommager le connecteur optique ou le port optique.
- Toujours utiliser des connecteurs optiques conformes aux spécifications, à défaut de quoi les ports optiques de l'AQ1000 pourraient être endommagés. Utiliser des connecteurs optiques homologués ou utilisés par les entreprises et les fournisseurs de services de télécommunications de votre région.
- Utiliser des connecteurs de câbles à fibre optique conformes à l'adaptateur universel et l'adaptateur de connecteur fournis (adaptateur universel indiqué par le suffixe).

#### **Utilisation de connecteurs de contact physique incliné SC (suffixe - ASC de l'unité OTDR)**

- L'embout à ferrule du connecteur de contact physique incliné SC est poli. Utiliser des câbles à fibre optique dont les connecteurs sont de même type. L'utilisation d'un autre type de connecteur peut endommager l'extrémité du connecteur.
- Utiliser exclusivement des adaptateurs universels de type SC (735482-SCC) sur les port OTDR, pour éviter d'endommager les ports optiques ou les connecteurs à fibre optique de l'AQ1000.

Clean the connector end face of the optical fiber cable before connecting it to the instrument. If dust is adhered to the connector end face, it may damage the instrument's optical port. If this happens, the instrument will not be able to make correct measurements.

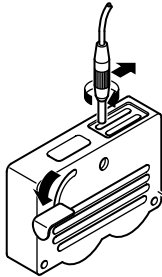

1. Firmly press the connector end face of the optical fiber cable against the cleaning surface of the cleaner.
2. While pressing the end face against the cleaner, turn the cable once.
3. While pressing the end face against the cleaner, move the cable.
4. Repeat steps 1 to 3.

You can purchase an optical fiber connector cleaner from NTT-AT Corporation.

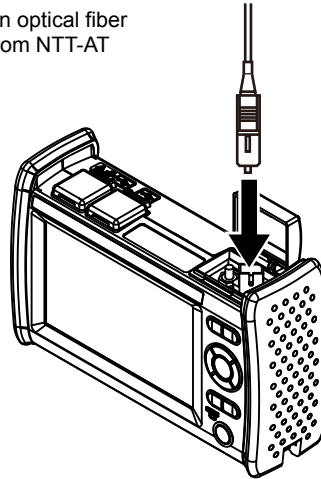

1. Open the optical port cover on the AQ1000 top panel.
2. Properly align the optical fiber cable's connector with the optical port, and insert the connector.

### Turning the Power On

Hold down the power switch on the instrument's front panel for at least 2 seconds. When the instrument starts normally, the power switch (POWER LED) lights, and the start screen appears.

#### When the Power-on Operation Does Not Finish Normally

Turn off the power switch, and check the following items.

- Is the USB-AC adapter connected correctly? See page 21.
- Are you holding down the power switch for at least 2 seconds?

If the instrument still does not work properly after checking these items, contact your nearest YOKOGAWA dealer for repairs.

#### Warm Up

To enable more accurate measurements, allow the instrument to warm up for at least 5 minutes after it is turned on.

#### Power-off and Sleep State

When the instrument is running normally with the power switch turned on, you can temporarily turn the power off to a sleep state. The operation varies depending on how long you hold down the power switch.

- Turning the Power Off

If you hold down the power switch for 3 seconds or longer, a shutdown message appears on the screen, the power is turned off completely, and the power switch (POWER LED) turns off.

- Sleep State

If you hold down the power switch for less than 3 seconds and release it, the screen turns off, and the instrument enters the sleep state. In this case, the power switch (POWER LED) remains on. To release the sleep state, hold down the power switch. In the sleep state, the instrument consumes the minimum amount of power. In the sleep state, the setup screen that you were using, the character input screen, or the like is retained. When you turn on the power switch again, the original screen is restored. If the sleep state continues for 2 hours, the power is turned off automatically.

# Screen Operations

## Screen Immediately after Power-on (Startup Window)

When you turn the instrument on and it starts, the start screen appears. There are three start screen display modes.

- Setup Info. Menu: The OTDR setup menu screen.
- Trace: The data display screen shows waveforms.
- Map: The data display screen shows icons.

### Setup Info. Menu screen

MEASURE SETUP

Wavelength	SM 1310nm
Distance Range	AUTO
Pulse Width	AUTO
Average Duration	AUTO
Auto Save	OFF
Fiber-In-Use Alarm	ON
Connection Check	OFF

EVENT ANALYSIS SETUP

Splice Loss	0.10dB
Return Loss	70dB
End of Fiber	3dB
Launch Fiber Setting	
Pass Fail Judgement	OFF
Macro Bending	OFF

Do not display from the next time

Switch to Trace screen

### Trace screen

Wavelength	SM 1550nm	Pulse Width	50ns	No. E	0.190dB/km
Distance Range	2km	MEASURE SETUP		Distance	1.43377km
				Splice Loss	
				Return Loss	50.651dB
				Cumm. Loss	0.707dB

Switch to Map screen

You can use the screen switch button to switch to the Trace screen or Map screen.

### Map screen

Wavelength	SM 1550nm	Pulse Width	50ns	No. 2	0.209dB/km
Distance Range	2km	MEASURE SETUP		Distance	0.87217km
				Splice Loss	0.060dB
				Return Loss	57.982dB
				Cumm. Loss	0.352dB

Switch to Trace screen

Switch to Map screen

For the procedure to select the start screen (Start Up Window), see section 8.3 in the User's Manual IM AQ1000-01EN.

Setup Info.Menu screen

This menu screen is for setting the measurement conditions and analysis conditions of the OTDR. Setup is possible using the same menu as the screen (OTDR Setup) explained in section 8.1 of the User's Manual IM AQ1000-01EN.

Tap the **MEASURE** display area to display a menu screen for setting measurement conditions.

Tap the **ANALYSIS** display area to display a menu screen for setting analysis conditions.

REAL TIME AVG Press keys to start measurement.

MEASURE SETUP	
Wavelength	SM 1310nm
Distance Range	<b>AUTO</b>
Pulse Width	<b>AUTO</b>
Average Duration	<b>AUTO</b>
Auto Save	<b>OFF</b>
Fiber-In-Use Alarm	<b>ON</b>
Connection Check	<b>OFF</b>

EVENT ANALYSIS SETUP	
Splice Loss	0.10dB
Return Loss	70dB
End of Fiber	3dB
Launch Fiber Setting	<b>OFF</b>
Pass Fail Judgement	<b>OFF</b>
Macro Bending	<b>OFF</b>

Do not display from the next time

TRACE MAP

Select this check box to display the Trace screen in the next startup.

Switches to the Map screen  
Switches to the Trace screen

For details on setting the measurement conditions (MEASURE) and analysis conditions (ANALYSIS), see section 8.1 in the User's Manual IM AQ1000-01EN.

### Measurement Screen (TRACE)

The OTDR measurement results are displayed as waveforms on the data display screen.

**Auto saving on indication**  
(See section 2.4 in the User's Manual IM AQ1000-01EN.)

**Power supply icon**  
(See page 22.)

**Mass storage device indication**  
USB connector icon appears instead of USB-AC adapter connection icon when a PC is connected to the type B (Micro-B) USB port of the AQ1000. (See page 15.)

**Switches to the MAP screen.**

**Event waveform display**

**Auto saving on indication**  
(See section 2.4 in the User's Manual IM AQ1000-01EN.)

**Power supply icon**  
(See page 22.)

**Mass storage device indication**  
USB connector icon appears instead of USB-AC adapter connection icon when a PC is connected to the type B (Micro-B) USB port of the AQ1000. (See page 15.)

**Switches to the MAP screen.**

**Waveform analysis results (marker/event)**  
(See sections 4.1 and 4.2 in the User's Manual IM AQ1000-01EN.)

Wavelength	Pulse Width	No. 2
SM 1550nm	50ns	0.209dB/km
Distance Range	MEASURE SETUP	Distance 0.87217km
2km		Splice Loss 0.060dB
		Return Loss 57.982dB
		Comm. Loss 0.352dB

## Measurement Screen (MAP)

The OTDR measurement results are displayed as icons on the data display screen.

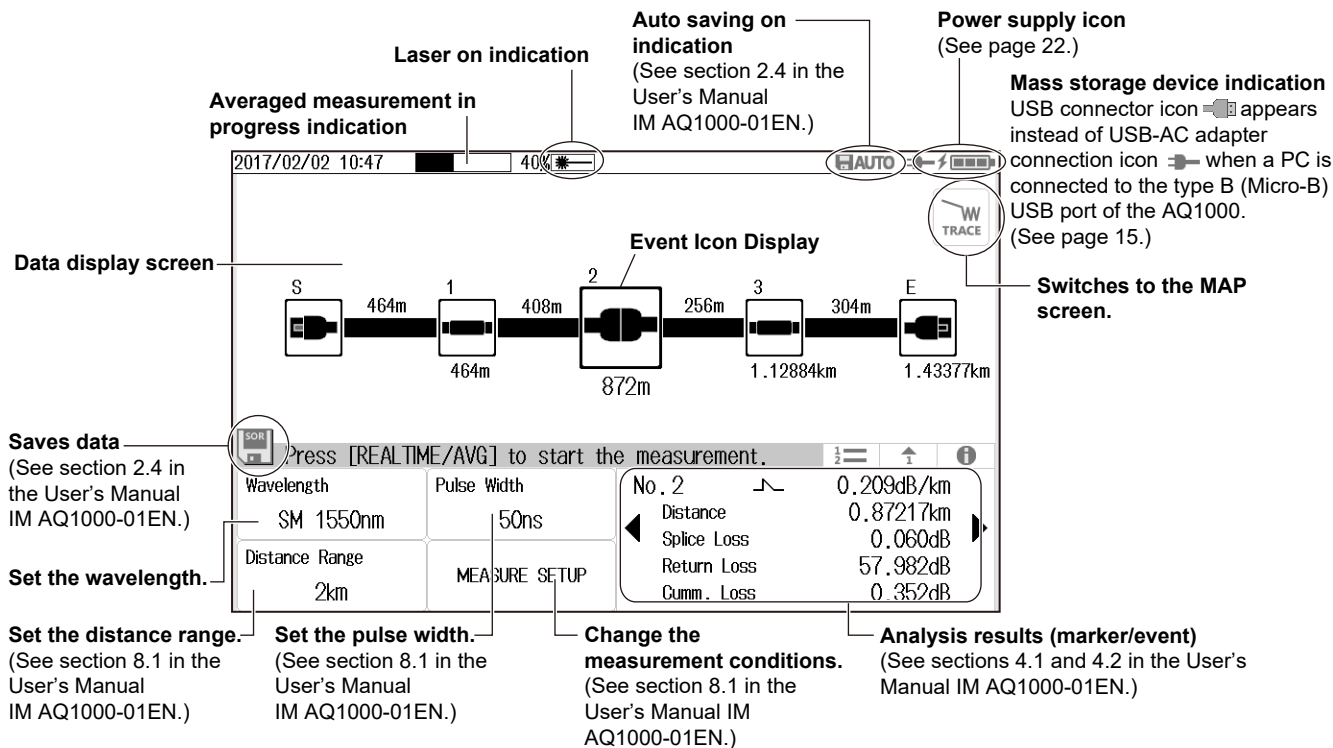

# MENU Screen

1. Press **MENU** to display the MENU screen.

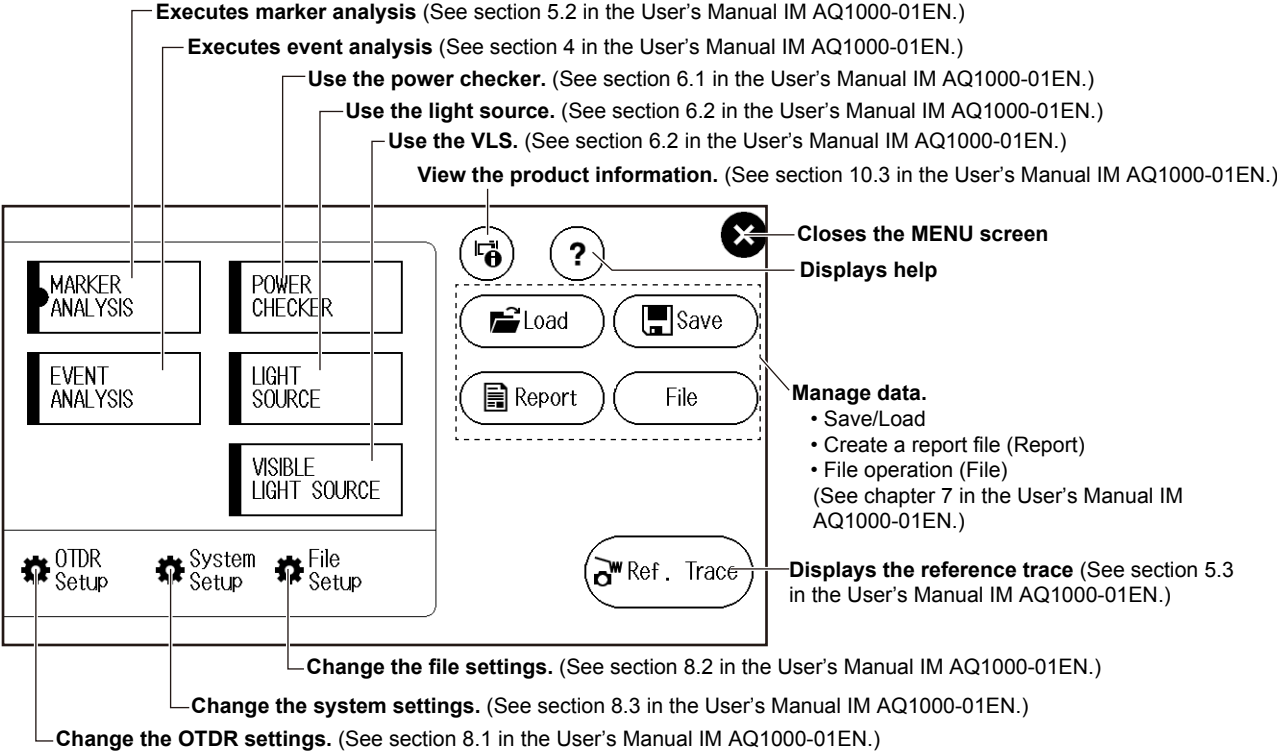

## Operating the Arrow Keys and CURSOR/ZOOM Key

### Operating the Settings

This section explains the operation of the **arrow** keys using the System Setup menu screen (partial extraction) as an example.

Use the up, down, right, and left arrow keys to move the cursor to the item you want to set.

The following setup operation patterns are available depending on the display button shape.

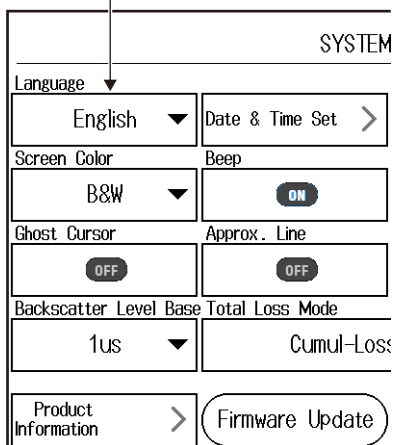

Press Enter to display the setup menu.

Items set from a list of options

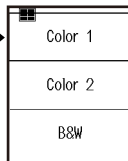

- Use the up and down arrow keys to move the cursor to the item you want to set.
- Press ENTER to confirm the selected item.

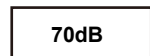

Items that require a value to be entered

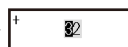

- To increase or decrease a value, use the up and down arrow keys. To move between digits, use the left and right arrow keys.
- The numeric key pad appears when you tap the key.
- Press ENTER to confirm the entered value.



Each time you press the key, the setting toggles between ON and OFF.

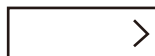

Press Enter to display the detailed setup screen.



Press Enter to confirm the selected item or execute its corresponding action.

### Cursor Operation and Zoom Operation

This section explains the operation of the **arrow** keys when you press **CURSOR/ZOOM**. Each time you press **CURSOR/ZOOM**, the mode switches between **CURSOR** and **ZOOM**.

**CURSOR mode: Use the left and right arrow keys to move the cursor. (TRACE screen) The cursor color changes to blue.**

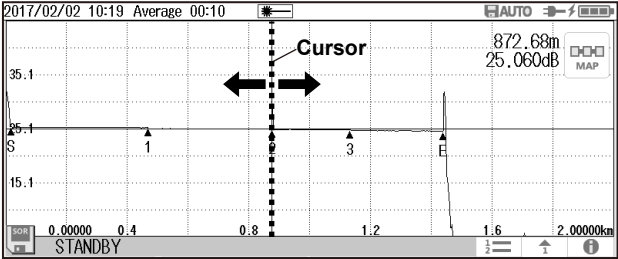

**CURSOR mode: Use the left and right arrow keys to select an icon. (MAP screen)**

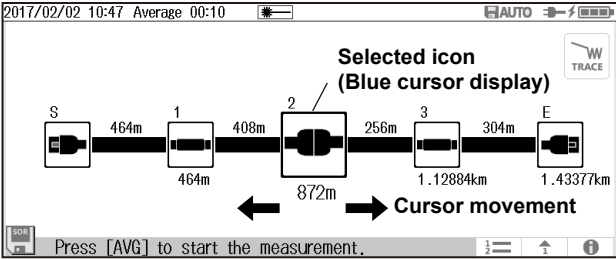

**ZOOM mode: Use the up, down, left, and right arrow keys to zoom in or zoom out of the waveform at the cursor position. (TRACE screen only) The outer grid color changes to blue.**

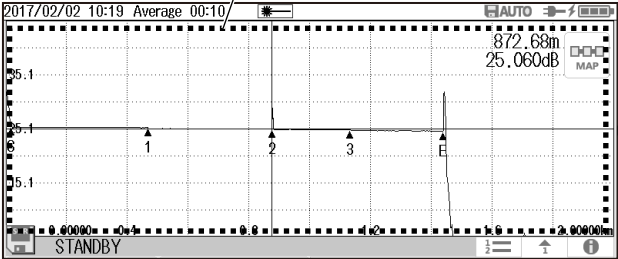

The behavior of the arrow keys is reversed depending on the zoom direction (Natural, Legacy) setting. For the setup, see section 8.3 in the User's Manual, IM AQ1000-01EN.

Use the left and right arrow keys to zoom in horizontally.  
Use the up and down arrow keys to zoom in vertically.

## Operating the Touch Panel

The basic touch panel operations are described below.

### Tap

Tap refers to the act of gently hitting the screen with your finger.

Tapping is used on the AQ1000 screen to select areas with a ► mark, close a setup menu, and so on.



### Drag

Drag refers to the act of pressing your finger against the screen and sliding your finger.

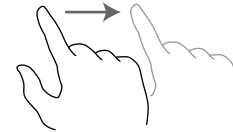

### Pinch out and pinch in

Pinch out refers to the act of pressing two fingers against the screen and spreading them apart. Pinch in refers to the act of pressing two fingers against the screen and drawing them together.

On a screen displaying waveforms, you can pinch out to zoom in and pinch in to zoom out.

Pinch out

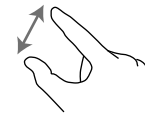

Pinch in

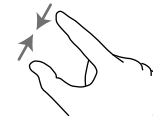

# Entering Text

When you select a setting, a character input dialog box appears if necessary. This section explains the operation after a character input dialog box is displayed.

## Entering Alphanumeric Characters

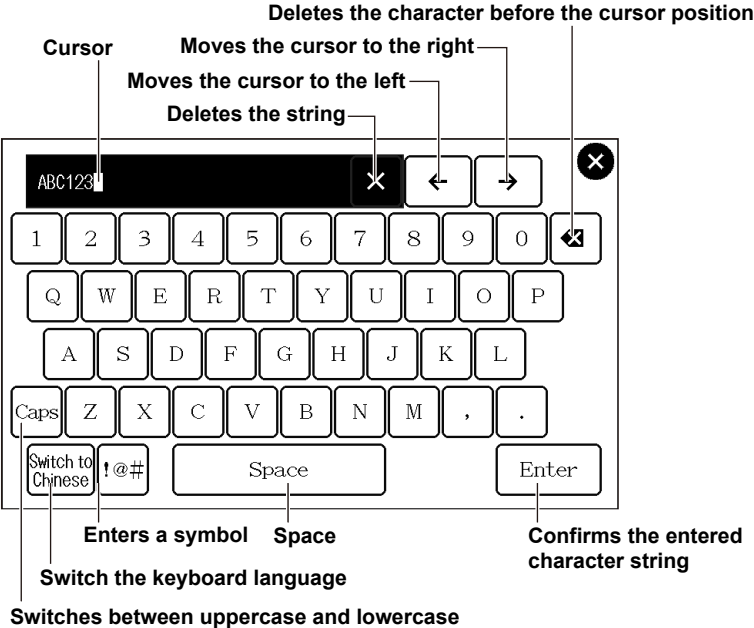

# Setting the Language and Date and Time

## Selecting the Language to Display

1. Press **MENU** to display the MENU screen.
2. Tap the **System Setup** display button to display the System Setup screen.
3. Tap the **Language** display button to display the language setup menu.

**MENU screen**

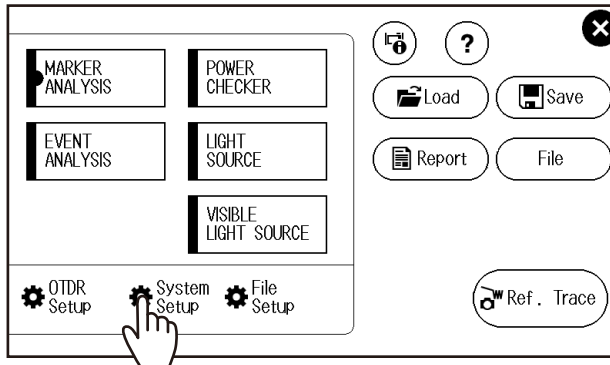

**System Setup screen**

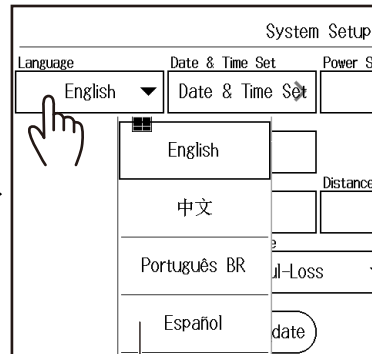

**Language setup menu**

## Selecting the Date and Time to Display

1. Press **MENU** to display the MENU screen.
2. Tap the **System Setup** display button to display the System Setup screen.
3. Tap the **Date & Time Set** display button to display the following screen.

The screenshot shows the 'Date & Time Set' screen with the following fields and callouts:

- Year, Month, and Day:** Three input fields containing '2017', '1', and '31' respectively. A callout points to these fields with the text: "Set the year, month, and day."
- Hour, Minute, and Second:** Three input fields containing '12', '4', and '43' respectively. A callout points to these fields with the text: "Set the hour, minute, and second."
- Type:** A dropdown menu showing 'yyyy/MM/dd HH:mm'. A callout points to this field with the text: "Set the date and time display format (Off, Year/Month/Day Time, Day/Month/Year Time, Year, Month (name), Day Time)."
- Set:** A button at the bottom right. A callout points to it with the text: "Set the AQ1000's date and time to the specified values. The set date and time are displayed in the upper left of the screen."

### Year, Month, and Date

The year is displayed according to the Gregorian calendar. The instrument supports leap years.

### Hour, Minute, and Second

The hour can be set to a value from 0 to 23.

# Averaged Measurement

## Performing Averaged Measurements

In averaged measurements, the data that is acquired from each pulse is averaged and displayed. By performing averaged measurements, you can improve the signal-to-noise (S/N) ratio. This is effective when you want to detect faint events that are buried in noise. Distance range and pulse width are set to their optimum values automatically at the start of an averaged measurement.

1. Tap the **Wavelength** display button to select the wavelength to be measured.
2. Press **AVG**. The measurement begins, and the measurement waveform is displayed on the data display screen. During measurement, a mark appears at the top of the display to indicate that the laser light is on.
3. When the average measurement is complete, the measurement stops automatically, and the events are analyzed automatically as well. When the measurement is complete, the laser on mark disappears. To stop an averaged measurement in progress, press **AVG**.

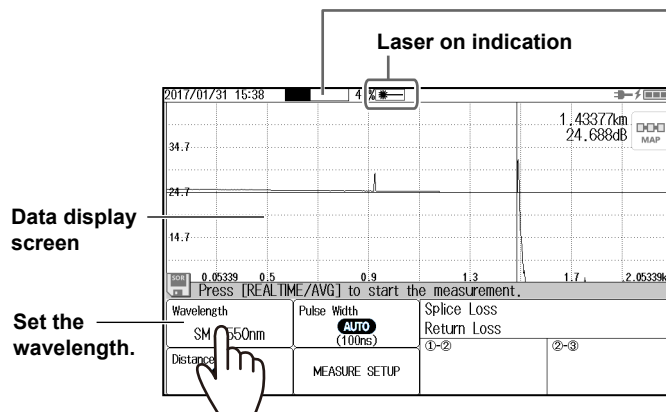

### Average progress

Displays the average progress.

The time it takes to complete a measurement varies depending on settings such as the distance range and the average time.

## Displaying the Event Analysis Results

### TRACE Screen

The numbers of detected events are displayed on the measured waveform.

Measurement reference point: S

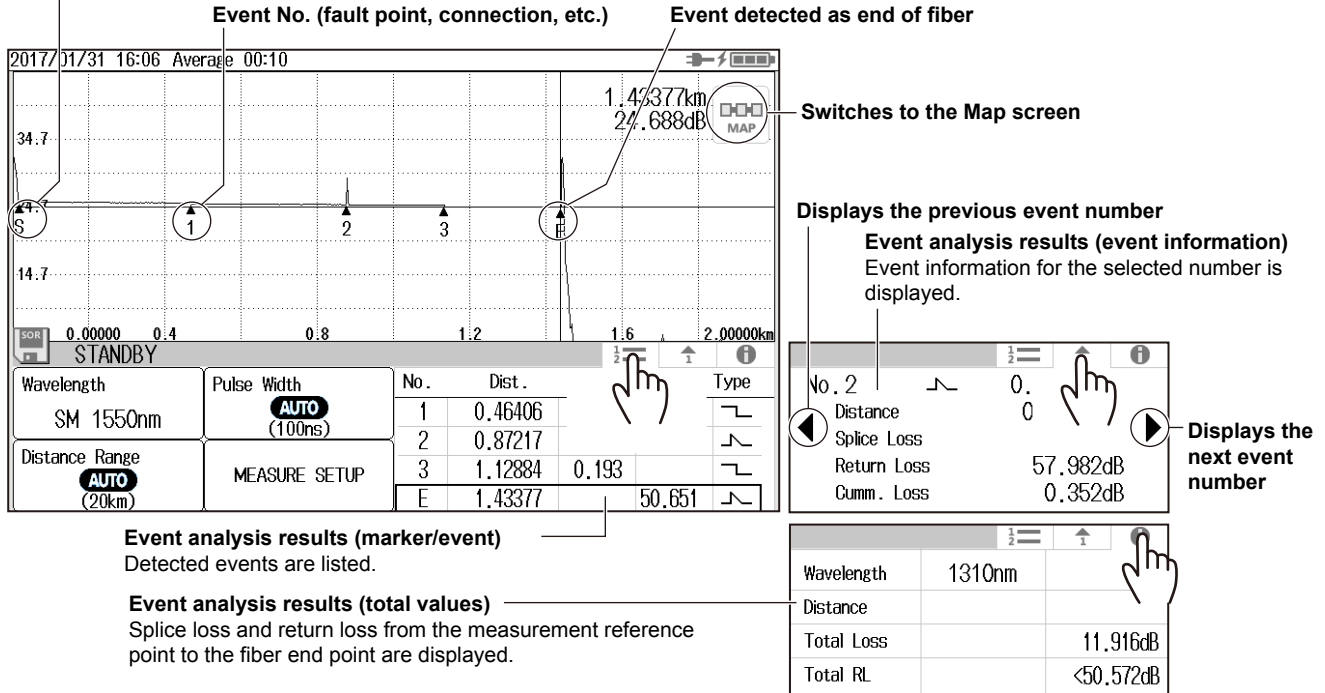

MAP Screen

The detected events are displayed on the measured waveform.

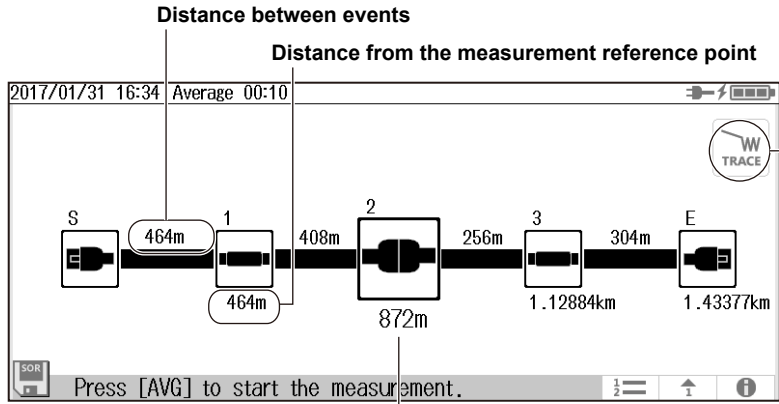

Switches to the waveform view.

Change the event type.

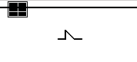
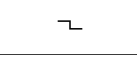
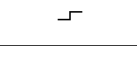
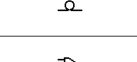
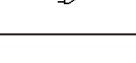
-  : Reflection
-  : Positive splice loss
-  : Negative splice loss
-  : Bending loss (macro bending)
-  : Splitter insertion loss

**Event Icon Display**

The event selected in the event analysis result display is shown at the center. Tapping the icon of another event on the screen will show that event at the center. You can move the icon horizontally by dragging the icon. You can change the event type by tapping the icon shown at the center.

# Analysis using the Emulation Software

Waveform data measured with the instrument can be analyzed on a PC by using the AQ7932 OTDR Emulation Software (version 6.01 or later). This software also has a report creation wizard that guides you through the steps, which is convenient for creating construction reports.

Waveform data saved in SOR format using the AQ1000 can be displayed on the PC using the emulation software.

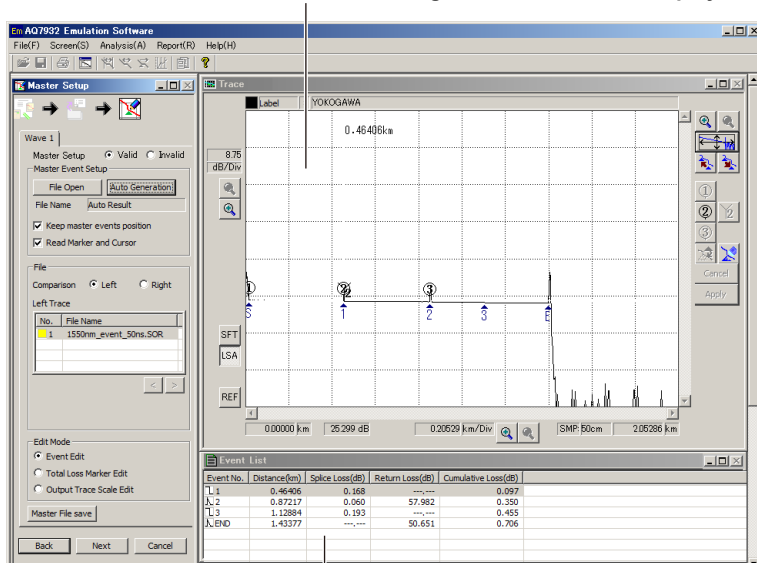

Analysis results (displays at list of events)

Create a construction report using the report creation wizard function of the emulation software.

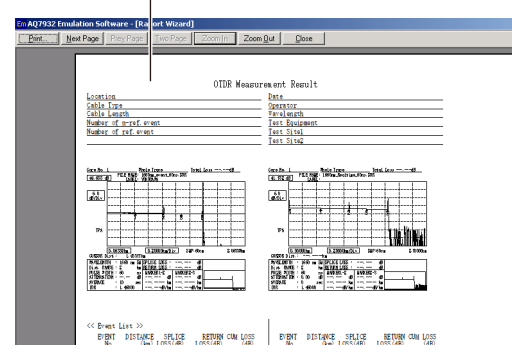

# Specifications

## Optical Pulse Measurement Section (OTDR)

Item	Specifications
Wavelength (nm) (typ.)	1310 ± 20/1550 ± 20
Compliant fiber	SM (ITU-T G.652)
Distance range (km)	0.2, 0.5, 1, 2, 5, 10, 20, 30, 50, 100, 200, 256
Pulse width (ns)	3, 10, 20, 30, 50, 100, 200, 300, 500, 1000, 2000, 5000, 10000, 20000
Sampling resolution	5 cm min.
Number of sampling points	256000 max.
Distance measurement accuracy (m)	± (1 m + measured distance × 2 × 10 <sup>-5</sup> ± 1 sampling resolution)
Event dead zone (m) <sup>†</sup>	≤ 0.8
Attenuation dead zone (m) <sup>††</sup>	4/5
Dynamic range (dB) (typ.) <sup>†††</sup>	32/30
Loss measurement accuracy	±0.03 dB/dB
Return loss measurement accuracy	±2 dB
Laser class <sup>††††</sup>	Class 1

† 3 ns pulse width, 55 dB or more return loss, at a point at 1.5 dB or less from the peak value under unsaturated conditions

†† 10 ns pulse width, 55 dB or more return loss, point where the backscattering light level is attenuated to a value within the regular value ± 0.5 dB, Typical.

††† SNR=1, 10 μs pulse width, 8 m sampling resolution, 3 minute measurement time, Typical

†††† Class 1: EN 60825-1:2014+A11:2021, IEC 60825-1:2014, GB/T 7247.1-2024

23°C ± 2°C unless specified otherwise

Typical values (typ.) are typical or mean values. They are not strictly warranted.

## Power Checker Section

Item	Specifications
Wavelength setting (nm)	1310/1490/1550/1625/1650
Power range (dBm)	-50 to -5
Measurement accuracy (dB) <sup>†</sup>	±0.5
Optical input port	OTDR port

† Power level: 100 µW (-10 dBm), CW light, wavelength: 1310 nm, light source spectral width: 10 nm or less, ambient temperature: 23°C±2°C, optical fiber: SM (ITU-T G.652), wavelength setting error: 0.5 nm or less, changes to the measuring instrument due to the passage of time are not included (add 1% a year after calibration)  
23°C ± 2°C unless specified otherwise

## Stabilized Light Source Section

Item	Specifications
Wavelength (nm)	1310 ± 25/1550 ± 25
Output	-3 dBm ± 1 dB
Stability (dB) <sup>†</sup>	±0.05
Modulation mode	CW, 270 Hz, 1 kHz, 2 kHz
Output port	OTDR port
Laser class <sup>††</sup>	Class 1

† Ambient temperature: A constant temperature within 23°C ± 2°C (for 5 minutes after a warm-up of 5 minutes)

†† Class 1: EN 60825-1:2014+A11:2021, IEC 60825-1:2014, GB/T 7247.1-2024

## Visible Light Source (VLS option)

Item	Specifications
Wavelength (nm)	650 ± 20
Output	-3 dBm or more (Peak)
Modulation mode	CW, 2Hz
Output port	VLS Port
Laser class <sup>†</sup>	Class 3R

† EN 60825-1:2014+A11:2021, IEC 60825-1:2014, GB/T 7247.1-2024  
23°C ± 2°C unless specified otherwise

## Specifications

### Common Specifications

Item		Specifications
Display section	Display	5.0 (inch size) color TFT LDC† (capacitive touch panel) Display pixels: 800 (horizontal) × 480 (vertical)
	LED	POWER (power supply on/off display), CHARGE (charge condition)
Input section	Input keys	Arrow keys, MENU key, REAL TIME key, AVG key, ZOOM/CURSOR key, ENTER key, power switch
	Touchscreen	Multi-touch capacitive
External interface	USB port	USB2.0 TypeA: Host Type B (Micro-B): USB mass storage device, DC power supply
	Wireless LAN (WLAN option)	IEEE802.11b/g/n (frequency band: 2.4 GHz)
Dimensions		185 mm (W) × 116 mm (H) × 56 mm (D) (excluding protrusions)
Weight		Approx. 660 g (including internal battery and protectors, excluding options)

† The LCD may include a few defective pixels.

There may be some pixels on the LCD that never light or are always lit (0.002% or less of the total number of display pixels including RGB). These pixels are not defects.

### OTDR Function

Item	Specification
Minimum readout resolution	Horizontal axis: 1 cm, Vertical axis: 0.001 dB
Group refractive index	1.30000 to 1.79999 (in 0.00001 steps)
Unit of distance	km, mile, kft
Backscatter level	Selectable: Pulse width = 1 μs or 1 ns
Measurement functions	Distance measurement, Loss measurement, Return loss measurement and Section Return loss measurement.
Analysis functions	Auto event search, Pass/Fail judgment
Others	Remote control with wireless LAN (Data transportation, Controlling the AQ1000 with browser of the PC or smartphone)

## General Specifications

Item		Specifications
Operating environment	Ambient temperature	-10°C to 50°C, (10°C to 35°C during battery charge <sup>†</sup> ), (0°C to 50°C when wireless LAN is in use)
	Ambient humidity	5 to 90%RH (no condensation)
	Altitude	4000 m or less
	In door use	In door use
Storage environment	Ambient temperature	-20°C to 60°C
	Ambient humidity	0 to 90%RH (no condensation)
Power supply	Rated supply voltage	5 VDC ± 10%, 1.5 A max., supplied through the type B USB port
Battery	Type	Lithium-ion polymer
	Operation time	10 hours or more (Telcordia GR-196-CORE Issue 2, September 2010)
	Charge time	Approx. 5 hours (typ.)
Warm-up time		At least 5 minutes
Pollution Degree <sup>††</sup>		POLLUTION degree 2
Laser safety class		OTDR, light source: Class 1 EN 60825-1:2014+A11:2021, IEC 60825-1:2014, GB/T 7247.1-2024, FDA 21CFR1040.10 and 1040.11
		VLS: Class 3R EN 60825-1:2014+A11:2021, IEC 60825-1:2014, GB/T 7247.1-2024, FDA 21CFR1040.10 and 1040.11
EMC	Emissions	Compliant standards: EN 61326-1 Class A, EN 55011 Class A Group1 EMC standards of Australia and New Zealand EN55011 Class A, Group 1 Korea Electromagnetic Conformity Standard ( 한국 전자파적합성기준 ) This is a Class A product. Operation of this product in a residential area may cause electromagnetic interference in which case the user will be required to correct the interference.
	Immunity	Compliant standard: EN 61326-1 Table2 (for use in industrial locations)
Wireless	/WLN option	RE directive: (HEALTH & SAFETY) EN62311, (SPECTRUM) EN300 328, (EMC) EN301 489-1, EN301 489-17, EN61326-1
		Indonesia Certification (Radio Wave Act), Korea Certification (Radio Wave Act), Thailand Certification (Radio Wave Act), Brazil Certification (Radio Wave Act), Singapore Certification (Radio Wave Act), United States Certification (Radio Wave Act), Mexico Certification (Radio Wave Act)
Environmental standards <sup>†††</sup>		Compliant standard: EU RoHS Directive compliant

## Specifications

- † The ambient temperature value during battery charge varies depending on the specifications of the USB-AC adapter in use.
- †† Pollution Degree applies to the degree of adhesion of a solid, liquid, or gas that deteriorates withstand voltage or surface resistivity. Pollution Degree 1 applies to sealed space (with no pollution or only dry non-conductive pollution). Pollution Degree 2 applies to normal indoor atmospheres (with only non-conductive pollution).
- ††† For conformity to environmental regulations and/or standards other than EU, contact your nearest YOKOGAWA office (PIM113-01Z2).  
Typical values (typ.) are typical or mean values. They are not strictly warranted.

# External Dimensions

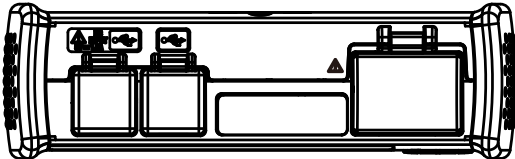

Unit: mm  
(approx. inch)

Unless otherwise specified, tolerance is  $\pm 3\%$   
(however, tolerances are  $\pm 0.3$  mm when below 10 mm).

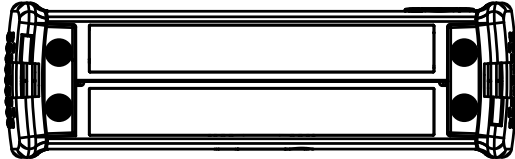
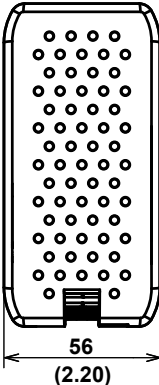
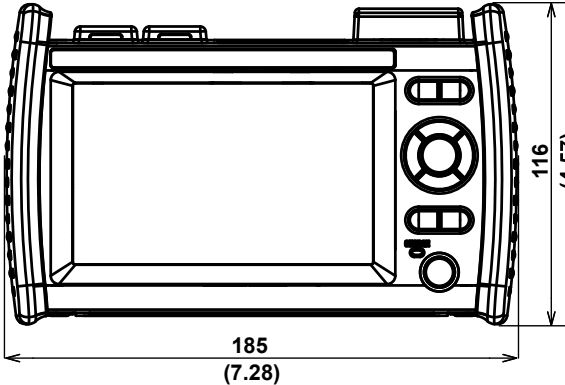

**Memo**

---