

### 1. Checking the Parts in the Kit

Confirm that all parts listed below are included in the kit. If any part is shorted or any abnormality is found in the appearance of the parts, contact our sales representative where you bought the instrument.

List of parts included in the kit :

Left side bracket(1 pc), right side bracket(1 pc), upper bracket(1 pc), flat-head screws(M4, 14 mm long) (2 pcs), flat-head screws(M3, 8 mm long) (1 pc), binding-head screws (M4, 14 mm long) (2 pcs), binding-head screws(M3, 8 mm long) (2 pcs), sealing labels(4 pcs)

### 2. Removing the Parts from the Instrument

#### Removing the Handle and Front Feet

1. To remove the handle from the instrument, tilt the handle vertically, but inclining it slightly to the rear, and pull the ends of the handle in the direction of the arrows in the figure below at the rotating joints.
2. To remove the front feet, unscrew the two screws (a) which fix the unit to the instrument.

#### Removing the Rear Feet

Remove the two sealing labels (b) and unscrew the two screws (c) which attach the rear feet to the instrument.

#### Removing the Sealing Labels

Remove the four sealing labels (d).

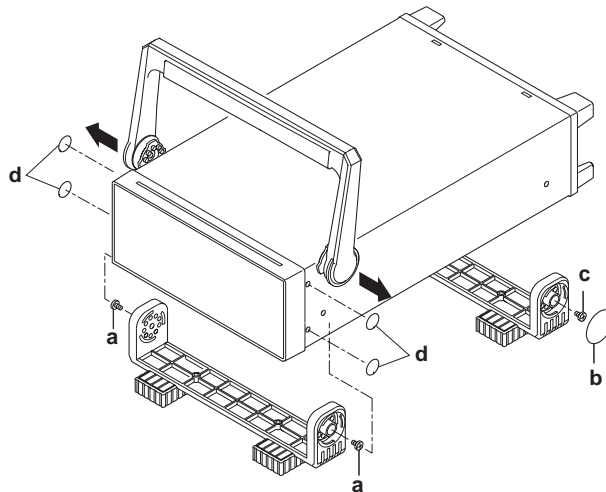

---

### 3. Joining the Right and Left Instruments with Mounting Hardware

1. Seal the four openings on the bottom plate to fix the feet with the four labels (1).
2. Using two flat-head screws (M4, 14 mm long) (3), screw the left side bracket (2) to the left side of the instrument.  
Reference torque value: 1.4 to 1.5 N·m
3. Using two binding-head screws (M4, 14 mm long) (7), screw the right side bracket (4) to the right side of the instrument.  
Reference torque value: 1.4 to 1.5 N·m
4. Screw the upper bracket (5) to the left side bracket (2) with a flat-head screw (M3, 8 mm long) (8) and to the right side bracket (4) with two binding-head screws (M3, 8 mm long) (6) in the appropriate positions.  
Reference torque value: 0.6 to 0.7 N·m

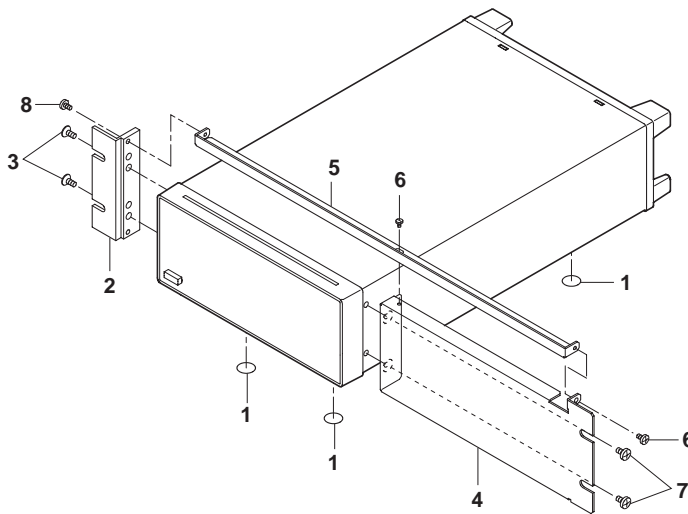

### 4. Mounting the Joined Instruments to the Rack

Dimensions after mounting to the rack are illustrated below.

**Note:** Be sure to place support beneath the rack.

