**User's
Manual**

**4-CH, 100 kS/s Accelerometer
Module
WE7235**

Foreword

Thank you for purchasing the WE7235 4-CH, 100 kS/s Accelerometer Module for the WE7000 PC-Based Measurement Instrument.

This User's Manual contains useful information about the function, connection to the measuring station, operations of the software on the PC, and troubleshooting of the WE7235. This manual assumes that you will be using the WE7000 Control Software that is included with the measuring station.

The manual listed below contains general information about the WE7000 (primarily describes the operations of the measuring station, the optical interface module, the optical interface card, and the WE7000 Control Software) and is included with the measuring station.

Manual Title	Manual No.
WE7000 User's Manual	IM 707001-01E

To ensure correct use, please read this manual thoroughly before beginning operation. After reading the manual, keep it in a convenient location for quick reference whenever a question arises during operation.

Notes

- **The contents of this manual describe WE7000 Control Software Ver. 4.2.0.0 and module software Ver. 3.01. The operating procedures and screen contents described in this manual may differ from those in other versions of the software.**
- The contents of this manual are subject to change without prior notice as a result of improvements in the software's performance and functions.
- Every effort has been made in the preparation of this manual to ensure the accuracy of its contents. However, should you have any questions or find any errors, please contact your nearest YOKOGAWA dealer as listed on the back cover of this manual.
- Copying or reproducing all or any part of the contents of this manual without the permission of Yokogawa Electric Corporation is strictly prohibited.

Trademarks

- Microsoft, Windows, and Windows NT are either registered trademarks or trademarks of Microsoft Corporation in the United States and/or other countries.
- Adobe and Acrobat are trademarks of Adobe Systems incorporated.
- IBM is a registered trademark of International Business Machines Corporation.
- All other company and product names used in this manual are trademarks or registered trademarks of their respective companies.

Revisions

1st Edition: October 2001

Checking the Contents of the Package

Unpack the box and check the contents before operating the instrument. If some of the contents are not correct or missing or if there is physical damage, contact the dealer from which you purchased them.

Measurement Module

Check that the model name given on the name plate matches those on the order.

MODEL

Model	Description
707235	WE7235 4-CH, 100 kS/s Accelerometer Module

NO. (Instrument Number)

When contacting the dealer from which you purchased the instrument, please quote the instrument No.

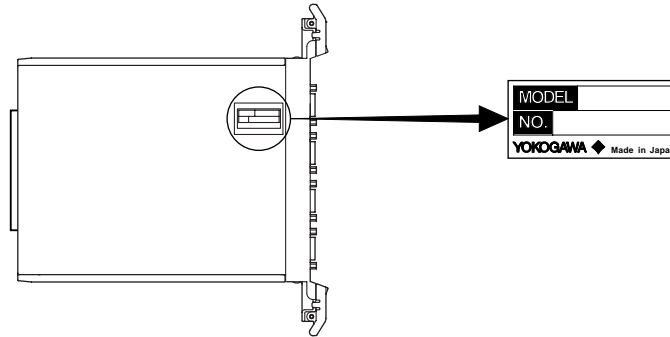

Standard Accessories

The standard accessories below are supplied with the instrument. Check that all contents are present and that they are undamaged.

User's manual (this manual) 1 piece
IM 707235-01E

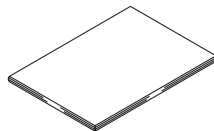

How to Use This Manual

Structure of the Manual

This user's manual consists of the following sections.

Chapter	Title	Description
1	Functions	Explains the system configuration and functions.
2	Hardware Preparation	Explains how to install the module into the measuring station and how to connect the input.
3	Troubleshooting and Maintenance	Explains the procedures for troubleshooting, performing acceleration sensor connection tests and self testing.
4	Specification	Explains the specifications of the module.
Index		

Conventions Used in This Manual

- **Units**

k Denotes "1000." Example: 100 kHz

K Denotes "1024." Example: 720 KB

- **Bolded Characters**

Characters written in bold mainly refer to on-screen elements and hardware controls.

- **Symbols**

The following symbols are used in this manual.



A symbol affixed to the instrument. Indicates danger to personnel or instrument and the operator must refer to the user's manual. The symbol is used in the User's Manual to indicate the reference.

WARNING

Describes precautions that should be observed to prevent injury or death to the user.

CAUTION

Describes precautions that should be observed to prevent minor or moderate injury, or damage to the instrument.

- **Note**

Provides important information for the proper operation of the instrument.

Contents

Foreword	1
Checking the Contents of the Package	2
How to Use This Manual	3
Chapter 1 Functions	
1.1 System Configuration and Block Diagram	1-1
1.2 Operation Panel	1-2
1.3 Setting Measurement Conditions	1-3
1.4 Setting the Trigger	1-7
1.5 Automatic Saving of the Measured Data, File Format Conversion, and Other Settings	1-8
1.6 Synchronizing to Other Modules Using the Bus Trigger/Time Base Signal	1-9
1.7 Names and Function of Sections	1-11
Chapter 2 Hardware Preparation	
2.1 Installing the Module into the Measuring Station	2-1
△ 2.2 Connecting Acceleration Sensors	2-3
△ 2.3 Connecting the Input Cable	2-5
Chapter 3 Troubleshooting and Maintenance	
3.1 Troubleshooting	3-1
3.2 Acceleration Sensor Connection Test	3-2
3.3 Self Test	3-4
3.4 Maintenance	3-5
Chapter 4 Specification	
4.1 Performance Specifications	4-1
4.2 Default Values (Factory Default Settings)	4-4
4.3 General Specifications	4-5
4.4 External Dimensions	4-6
Index	Index-1

1.1 System Configuration and Block Diagram

System Configuration

The following is an example in which the WE7235 4-CH, 100 kS/s Accelerometer Module is installed into the measuring station and the measuring station is connected to the PC with the optical fiber cable.

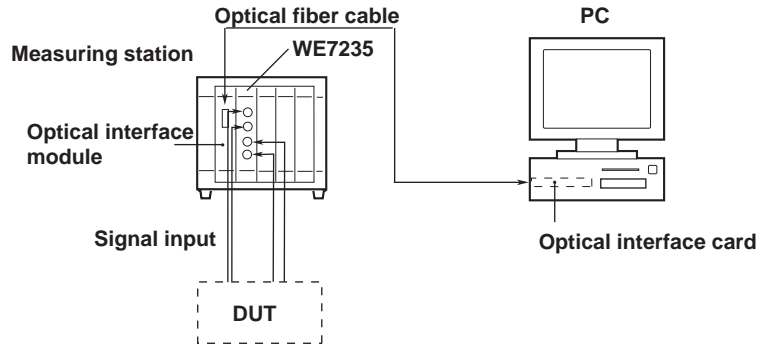

Block Diagram

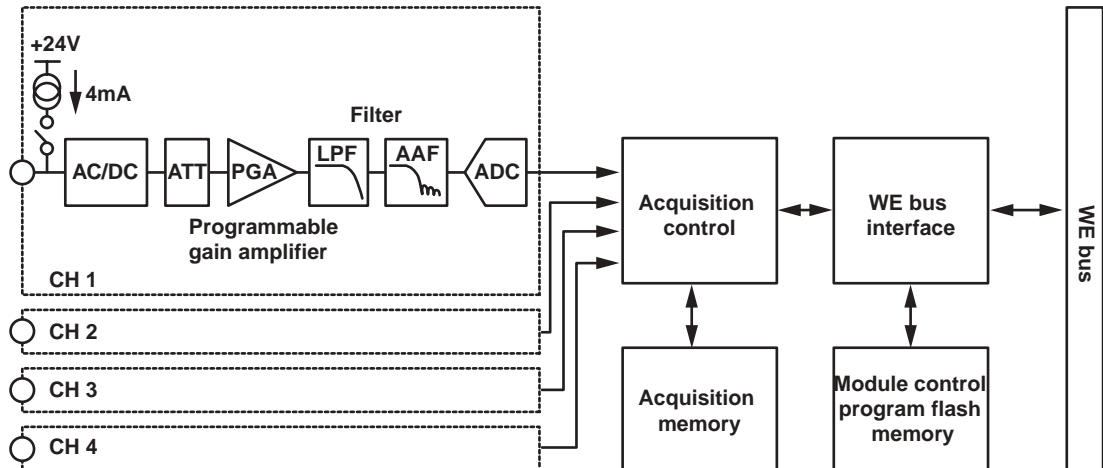

Description of Operation

This module can measure the acceleration signal and voltage received from built-in amplifier type acceleration sensors.

In acceleration measurement, the module supplies a 4-mA driving current to the built-in amplifier type acceleration sensor. The output signal from the built-in amplifier type acceleration sensor is the sum of the DC bias voltage and the AC acceleration signal voltage. The AC coupling circuit extracts only the acceleration signal component from the signal and passes the resultant signal to the programmable gain amplifier.

In voltage measurement, the voltage signal applied to each channel goes through the AC/DC coupling circuit and attenuator (ATT) as necessary. It is, then, passed to the programmable gain amplifier where the voltage amplitude is adjusted.

Next, the input signal goes through the low-pass filter (LPF) and the anti-aliasing filter (AAF) and enters to the A/D converter (ADC). In the A/D converter, the input signal is sampled by synchronizing to the clock provided by the time base and converted to digital data.

The digital data is then stored in the acquisition memory according to the sampling interval and the trigger condition settings.

The data in the acquisition memory can be read from the PC.

1.2 Operation Panel

The WE7000 Control Software that is installed in the PC is used to control the WE7235 4-CH, 100 kS/s Accelerometer Module. The WE7000 Control Software displays operation panels similar to those shown in the figure below. This user's manual does not explain the operations of the operation panel or waveform monitor. For the operations of these items, see the on-line help that is provided with the WE7000 Control Software.

Setting the Measurement Conditions

Turn measurement ON/OFF

Turn ON/OFF the supply current to the acceleration sensor

Select the input coupling

Select measurement unit

Select the measurement range/gain

Set the acceleration sensor sensitivity

Start/Stop measurement

Turn ON/OFF waveform monitor

Select the check box during continuous measurements (only during the trigger mode)

Switch to the window used for detailed configuration

Set the sampling interval

Select the acquisition mode

Set the number of acquisitions (Number of memory block used)

Set the record length

Set the number of memory partitions

More Option

Setting the Trigger

Displayed when More Option clicked

Select the trigger type

Set the trigger level

Displayed when the Trig tab is clicked

Trig tab

Select the trigger source

Select the trigger combination

Enable overlap acquisition

Set the trigger hold off

Set the pretrigger

Other Settings

Displayed when More Option clicked

Set the input filter

Displayed when the Trig tab is clicked

Select the time base

Select the number of measurement channels

1.3 Setting Measurement Conditions

Turning ON/OFF the Measurement Channel

Measurement is made only on the channels that have the On check box selected. If 1CH or 2CH is selected in the section "Selecting the Number of Measurement Channels" as described later, only the specified number of channels can be selected.

Turning ON/OFF the Supply Current to the Acceleration Sensor (Bias)

When measuring acceleration, a 4-mA current is supplied to the acceleration sensors for those channels that have the Bias check box selected. Select the **Bias** check box after connecting the acceleration sensors.

Input Coupling

Select which component of the input signal is to be acquired.

AC: Acquire only the AC component of the input signal.

DC: Acquires all the components (DC and AC) of the input signal.

When measuring acceleration, only AC is selectable.

Measurement Unit

Set the unit for the item being measured.

When measuring acceleration

m/S2(m/s²)

G

When measuring voltage

V

Measurement Range/Gain

Two types of input signals can be measured: acceleration and normal voltage.

You can select from the following measurement ranges/gain.

Acceleration Measurement (Gain)

Setting	Note
×1	Corresponds to the ±5-V range of voltage measurement
×2	Corresponds to the ±2.5-V range of voltage measurement
×5	Corresponds to the ±1-V range of voltage measurement
×10	Corresponds to the ±500-mV range of voltage measurement
×20	Corresponds to the ±250-mV range of voltage measurement
×50	Corresponds to the ±100-mV range of voltage measurement
×100	Corresponds to the ±50-mV range of voltage measurement

Voltage Measurement (Range)

Setting	Measurable Range (Accuracy Guaranteed Measurement Range)
50 mV	±50 mV
100 mV	±100 mV
250 mV	±250 mV
500 mV	±500 mV
1 V	±1 V
2.5 V	±2.5 V
5 V	±5 V
10 V	±10 V
25 V	±25 V
50 V	±50 V

Acceleration Sensor Sensitivity

Enter the sensitivity of the acceleration sensor to be used. If you click **More Option** and display the detailed configuration dialog box, the measurement unit is not displayed.

Input Filter

The two types of filters, the low-pass filter and the anti-aliasing filter, can be used to remove high frequency noise from the input signal. Select the low-pass filter setting from 40 Hz, 100 Hz, 400 Hz, 1 kHz, 4 kHz, 10 kHz, 40 kHz, and OFF. Select the anti-aliasing filter setting from 20 Hz, 40 Hz, 80 Hz, 200 Hz, 400 Hz, 800 Hz, 2 kHz, 4 kHz, 8 kHz, 20 kHz, 40 kHz, and OFF after selecting the **AAF** check box.

Acquisition Mode

Select the measurement data acquisition method from the following four modes:

Triggered (Trigger Mode)

Click **Start**. The measured data is acquired to the acquisition memory according to the specified trigger condition. After acquiring the specified record length of data, the operation stops. If the **Repeat** check box* is selected, the operation repeats until the next time Start is clicked.

* The Repeat check box appears only when the expression “optimal number of memory partitions $\geq 2 \times$ the number of measurements” is satisfied. The “optimal number of memory partitions” refers to the number of partitions that is used as a matter of convenience inside the module. In some cases, the memory can be partitioned into smaller sections depending on the record length and the number of channels. In such cases, the maximum possible number of partitions is determined, and this value is taken to be the “optimal number of memory partitions.” The optimal number of memory partitions is the largest value of 2^n which is smaller than “ $4,194,304 / (\text{the number of channels specified for the channel mode} \times \text{the record length})$.” For example, if the channel mode is 2CH and the record length is 10000, the calculation is $4,194,304 / (2 \times 10000)$ which is approximately 210. In this case, the optimal number of partitions is 128. Thus, if the number of acquisitions is less than or equal to 64, the Repeat check box appears. If it is larger than 64, the check box does not appear. If the optimal value exceeds 256, the number of partitions is set to 256.

Free Run (Free Run Mode)

Click **Start**. The measured data is acquired immediately to the acquisition memory. If Start is clicked again, the operation stops.

Gate (Level) (Gate (Level) Mode)

The measurement data is acquired during the time that the specified trigger condition is satisfied (gate period). If the specified record length of data is acquired before the gate period ends, the acquisition stops at that point. The operation repeats the number of times specified by the number of acquisitions. If you stop the measurement before this number is reached, the operation stops immediately.

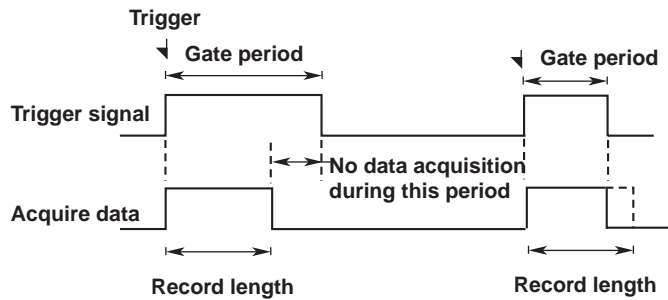

Gate (Edge) (Gate (Edge) Mode)

Data acquisition starts when the specified trigger condition is satisfied and pauses when the trigger condition is no longer satisfied. When the trigger condition is satisfied again, data acquisition starts at a new memory block. The operation repeats the number of times specified by the number of acquisitions. If you stop the measurement before this number is reached, the operation stops immediately.

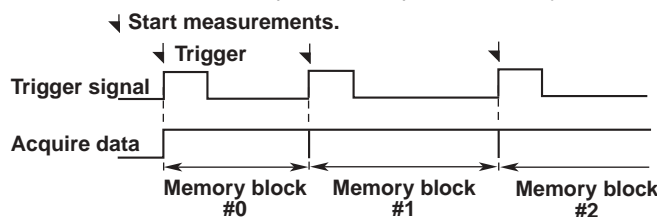

Sampling Interval

During trigger/gate mode

You can select the sampling interval in the range from 10 μ s to 10 s (in 1- μ s steps).

During free run mode

You can select the sampling interval in the range from 1 ms to 10 s (in 1- μ s steps).

Note

You can set the sampling frequency of the time base for the FFT by using the WE Control API (sold separately, model: 707741). This function is not supported on the WE7000 Control Software. For details, see the WE Control API User's Manual (IM707741-61E).

Memory Partition (valid only during the trigger mode)

During the trigger mode, you can divide the acquisition memory into multiple blocks and acquire the data to the memory blocks in order every time the trigger occurs. You can divide the memory into 1/2/4/8/16/32/64/128/256 partitions. When using memory partitions, if the measurement is stopped before reaching the number of acquisitions, the data in the memory block that was being written at that time are invalid.

Record Length (valid only during trigger/gate (level) mode)

The term "record length" refers to the number of data points acquired in the acquisition memory. The maximum record length (number of acquired data points) when the memory is not partitioned is 4 Mwords for 1 channel, 2 Mwords for 2 channels and 1 Mword for 3 or 4 channels.

The range during the trigger mode is "2 to 4 M/the number of memory partitions," "2 to 2 M/the number of memory partitions," and "2 to 1 M/the number of memory partitions" when the number of measurement channels is 1, 2, and 3 or 4, respectively. The record length is set to "Maximum record length/the number of memory partitions" when 0 is specified in the trigger mode.

The range during the gate (level) mode is "2 to the maximum record length." The record length is set to the "Maximum record length" when 0 is specified in the gate (level) mode. In this case, the memory is partitioned according to the satisfied and unsatisfied conditions of the trigger. The maximum number of memory blocks that can be created in this way is 256.

For the minimum record length, "the record length \times sampling interval" cannot be less than 5 ms. When using the internal clock as the time base, the record length is set to the minimum allowed value when a value below this minimum value is specified. However, this restriction is not enforced when using the external clock as the time base. In this case, the value is set to the specified value, but proper measurements may be impeded.

Number of Acquisitions (No. of Acquisitions)

You can specify the number of times to acquire the data when using the trigger or gate mode. The range is from 1 to 32,768 times. However, if the specified record length is greater than or equal to "the maximum record length/2," you can only specify one for the number of acquisitions.

After acquiring the number of acquisitions of data or if the acquisition is stopped, the waveform of the measured data is displayed. For example, if you set the number of acquisitions to 3 in the trigger mode, the module operates as follows.

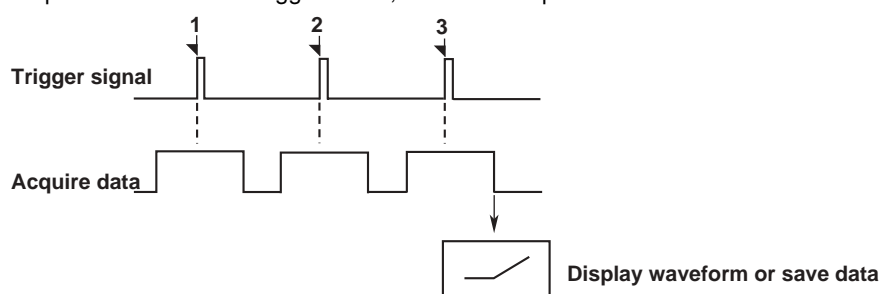

If you set a number less than the number of memory partitions in the trigger mode, you will have to specify the number of memory blocks to use. If you set a number larger than the number of memory partitions, the data is acquired until the specified number is reached or until the specified record length is reached.

In the gate mode, measured data is acquired by taking the specified record length to be one block. When the specified record length is “maximum record length/256” or less and the number of acquisitions is set to 256 or less, all of the acquired data are saved. However, if the number of acquisition is set above 256, the acquired data beyond the 256th acquisition overwrites the previous data starting from the first acquisition. If the record length is set above “maximum record length/256” points, the data is overwritten when the number of acquisitions exceeds (maximum record length/specified record length).

Note

- If the number of acquisitions is greater than the number of memory partitions in the trigger mode, only the last “number of memory partitions” blocks of measured data are saved. In addition, you can only specify 1 for the number of acquisitions if the number of memory partitions is set to 1.
 - If (the number of acquisitions × record length × the number of measurement channels) is “4M” points or less, and the number of acquisitions exceeds 256, then only the last 256 blocks of measured data are saved. If (the number of acquisitions × record length × the number of measurement channels) exceeds “4M” points, only the last “4M/(record length × the number of measurement channels)” blocks of measured data are saved. (* When the number of measurement channels is 3, it is considered to be 4.)
 - If the specified record length is greater than or equal to “the maximum record length/2” in the gate mode, you can only specify 1 for the number of acquisitions.
 - You can set 0 by using the WE Control API (sold separately, model: 707741). If you select 0, the acquisition of data continues until the measurement is stopped or the specified record length of data is acquired. This function is not supported on the WE7000 Control Software. For details, see the WE Control API User’s Manual (IM707741-61E).
-

Number of Measurement Channels (CH Mode)

The maximum record length can be changed by restricting the number of measurement channels. The number of measurement channels can be set to 4 channels (no restriction), 2 channels, or 1 channel. The maximum record length is set to 1 Mword for 4 channels, 2 Mwords for 2 channels, and 4 Mwords for 1 channel.

Time Base

You can select whether to sample the input signal with the specified sampling interval based on the module’s internal clock or to sample with the time base signal (CMNCLK)* of the measuring station (BUSCLK setting).

* For setting procedures, see section 4.6 “Setting the Trigger Source/Time Base/Arming” in the WE7000 User’s Manual (IM707001-01E).

Note

You can set the time base for the FFT by using the WE Control API (sold separately, model: 707741). This function is not supported on the WE7000 Control Software. For details, see the WE Control API User’s Manual (IM707741-61E).

1.4 Setting the Trigger

Trigger Source (Source)

Select the signal for triggering. Select one from the following list of choices:

Internal: Input signal (includes input signals from 4-CH, 100 kS/s Accelerometer Modules that are linked)

BUSTRG: Bus signal (BUSTRG1/BUSTRG2) of the WE bus

Trigger Type (Trig Type)

If the trigger source is set to the input signal, select the trigger type from the following list of choices.

Only High, Low, and Off can be selected in the gate (level) mode.

Rise: Rising (edge trigger)

Fall: Falling (edge trigger)

Both: Both rising and falling (edge trigger)

High: High level (state trigger)

Low: Low level (state trigger)

Off: No trigger

Trigger Level (Trig Level)

The operation varies depending on the item being measured. When measuring acceleration, set the trigger level in terms of a percentage (+100% to -100%) with respect to \pm full scale. When measuring voltage, set the trigger level using a voltage level. The selectable ranges are as follows: 0.1 mV for the ± 50 -mV measurement range, 1 mV for the ± 100 -mV, ± 250 -mV, and ± 500 -mV measurement ranges, 10 mV for the ± 1 -V, ± 2.5 -V, and ± 5 -V measurement ranges, and 100 mV for the ± 10 -V, ± 25 -V, and ± 50 -V measurement ranges.

Trigger Combination (Combination)

Select one from the following list of choices:

OR trigger

The trigger occurs if any one of the trigger conditions specified for the input signal of each channel is satisfied.

AND trigger

The trigger occurs when all of the trigger conditions specified for the input signal of each channel are satisfied.

Pretrigger (valid only during trigger mode)

You can acquire the measured data before the trigger point into the acquisition memory.

Set how many points before the trigger point to begin the acquisition in the range, "0 to the specified record length - 2."

Trigger Hold Off (Hold Off) and Overlapped Acquisition

Select the trigger hold off period that is used to temporarily stop the detection of the next trigger once a trigger occurs. With the factory default setting, the next trigger detection does not occur until the record length of data is stored in the acquisition memory (overlapped detection disabled). Therefore, the hold off period is set in the range from "the record length to 4,194,304." If the overlapped acquisition is enabled, however, the hold off period can be set in the range from "2 to 4,194,304." In some cases, the measurement stops when the trigger hold off is set to 1/255 of the record length or less. In this case, set the value above 1/255 of the record length.

Manual Trigger

If you select the trigger mode or the gate mode, triggers can be generated at arbitrary times. The method used to acquire the data after the trigger is activated varies depending on the mode. However, this function is not supported on the WE7000 Control Software. It can be used with the WE Control API (sold separately, model: 707741).

1.5 Automatic Saving of the Measured Data, File Format Conversion, and Other Settings

The following functions are functions of the WE7000 Control Software. For the operations of these items, see the on-line help that is provided with the WE7000 Control Software.

Automatic Saving of Waveform Data

In addition to saving the data displayed on the waveform monitor, you can also have the waveform data automatically saved using a trigger or save the data continuously in free run mode.

During Trigger/Gate Mode

There are two methods of saving the measured values.

- Cyclic
You specify the number of files, and the data are saved in a cyclic pattern within the specified number of files until the measurement is stopped. The newest data are not the file with the largest file number, but the file to which the data were saved immediately before stopping the measurement.

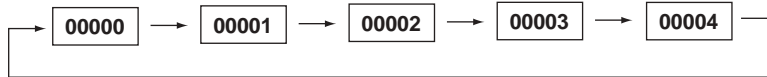

- File number limit
You specify the number of files, and the data are saved up to the specified number and then the operation stops.

During Free Run Mode

You can select to save the data to one file or to multiple files such as by specifying the number of data points.

Converting Waveform Data

Waveform data that are saved can be converted to ASCII data in CSV format (*.csv) or to a physical value in 32-bit floating point format (conforming to IEEE754-1985) (*.wvf). This file conversion can also be performed on data saved with the waveform monitor.

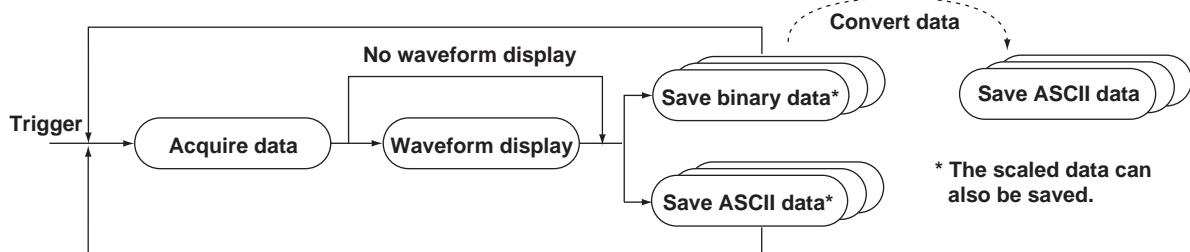

Scaling the Measured Data

Set the measured values at any two points (VP1 and VP2) and their corresponding physical values (SP1 and SP2) or set the scaling coefficient (a) and offset value (b) to define the scale conversion equation ($Y=ax+b$). The measured values are converted to physical values according to this equation, and the waveform display and saving operations are carried out.

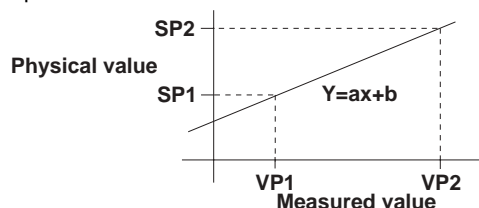

1.6 Synchronizing to Other Modules Using the Bus Trigger/Time Base Signal

Input/Output of Bus Trigger Signals

The WE7235 4-CH, 100 kS/s Accelerometer Module can output bus trigger signals based on the results of comparing the input signal with the threshold (see 1.4 “Setting the Trigger” for details on how to set the trigger). Because the comparison between the input signal and the threshold is done in sync with the time base signal, the bus trigger signal changes in sync with the time base signal and “True” is output during the time the trigger conditions are satisfied.

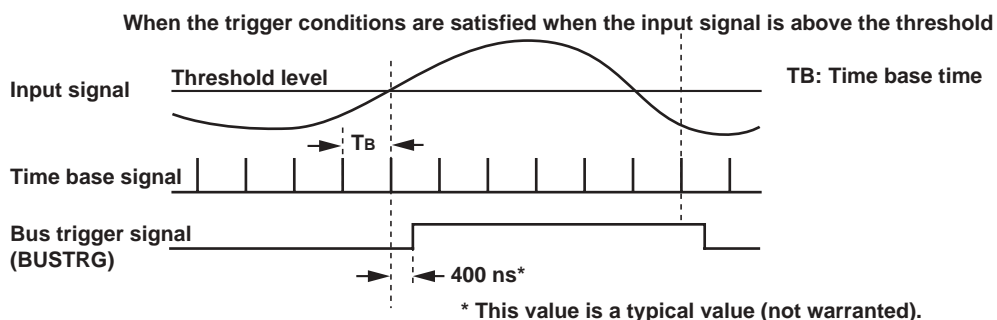

The WE7235 can also acquire data by following the bus trigger signal. If the bus trigger signal becomes “True” between the “False” to “True” edge and the “True” to “False” edge of the time base signal, then the trigger is considered to have been satisfied by the data sampled with the time base signal. Note the following when making multiple acquisitions in the trigger mode: Because the bus trigger signal is detected on the level of the signal, if the duration in which the bus trigger signal remains “True” is longer than the hold off period, the next acquisition starts after the hold off period.

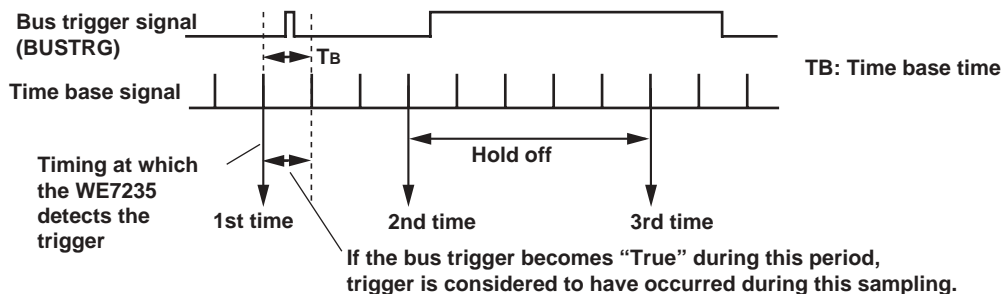

In addition, the WE7235 can output a bus trigger signal upon detecting a trigger within the module, and receive the results of the AND/OR computation on the bus to trigger the actual trigger operation.

Input/Output of Time Base Signals

While the data acquisition is in progress, the time base signal generated by the internal clock of the WE7235 can be output to the time base signal bus (CMNCLK) in the measuring station. The time difference between the internal clock and the time base signal (CMNCLK) is approximately 100 ns (typical value[†]).

Conversely, the WE7235 can input and synchronize to the time base signal (CMNCLK) on the bus in order to sample the input signal. If the period of the time base signal is shorter than the setting range of the sampling interval (see 1.3 “Setting the Conditions for Acquiring the Waveform”), the time base signal is sometimes ignored and the sampling does not occur. The delay from the time the time base signal enters the WE7521 to the time the sampling starts is approximately 80 ns (typical value[†]).

* The typical value is a representative or standard value. It is not a warranted value.

Controlling the Timing of the Start of the Measurement (Arming)

When the arming signal (ARM) bus is connected to the measurement module in the trigger source/time base source/arming setting dialog box, clicking **Start** on the operation panel causes the module to enter the arming signal wait state. The measurement starts when the arming signal becomes True.

If the Repeat check box of the Start button is selected, the module enters the arming signal wait state after each measurement. When the arming signal becomes True again, the module acquires the next waveform.

1.7 Names and Function of Sections

Front Panel

Sampling indicator
Turns ON when the input signal is sampled.

Input connector
BNC terminal used to input the signal to be measured.

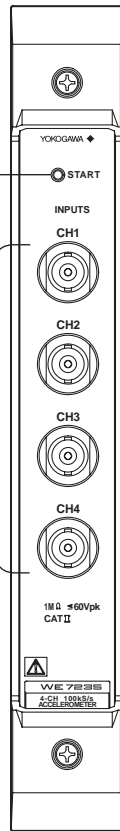

2.1 Installing the Module into the Measuring Station

Preparing to Install the Module

The measuring station comes with each slot covered with a cover plate as shown in the figure below. Verify that the power supply is not connected to the measuring station, and then loosen the module attachment screws (2 locations) and remove the cover plate from the slot where the module is going to be installed. Please note that the slot on the left end is dedicated to the communication module and therefore this module cannot be installed there.

* The following figure shows an example of the measuring station WE400.

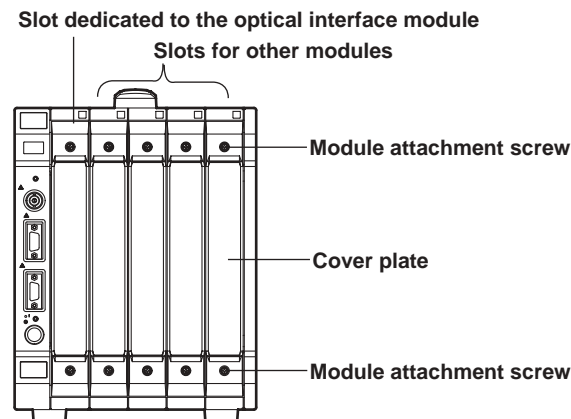

Installing the Accelerometer Module

WARNING

- Make sure to fasten the top and bottom attachment screws. If you connect the input signal cable without fastening the attachment screws, the protective grounding of the measurement module provided by the power cord is compromised and may cause electric shock.

CAUTION

- To avoid damaging the instrument when installing or removing modules, make sure to turn OFF the standby power switch of the measuring station.
- Be careful not to get your fingers caught in the ejection lever when inserting the module. In addition, do not put your hand inside the slot, because there are protrusions along the module guide that may injure your fingers.
- Do not remove the cover plates from unused slots. It can cause overheating and malfunction. The cover plates are also needed to minimize the influence of electromagnetic interference.

Insert the module along the guide rail of the slot from which you removed the cover plate. Insert the module until it clicks into the connector. Be careful not to get your fingers caught in the ejection lever while inserting the module. When the module is securely inserted, fasten the module attachment screws (tightening torque: 0.6 to 0.7 N-m). To remove the module, loosen the module attachment screws and pull the ejection lever from the inside to the outside. This will force the module out of the slot.

<There is an illustration on the next page.>

2.1 Installing the Module into the Measuring Station

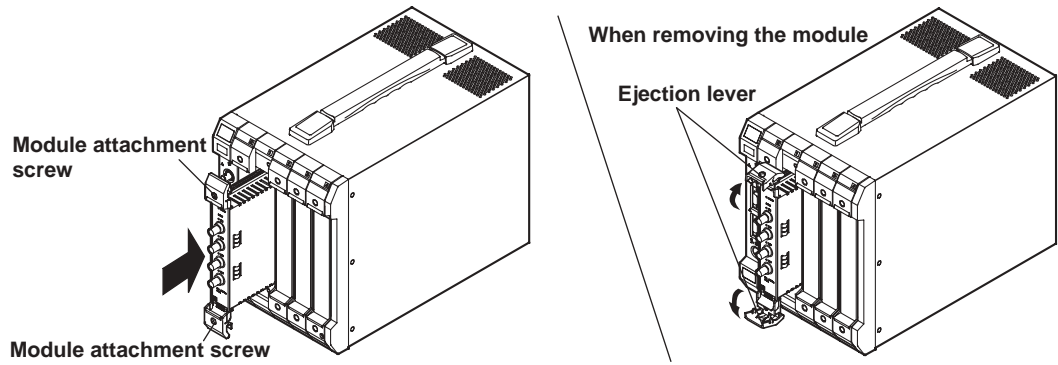

Note

When synchronizing accelerometer modules for measurement (module linking), install the multiple accelerometer modules in adjacent slots.

2.2 Connecting Acceleration Sensors

When measuring acceleration, connect acceleration sensors. For a description on acceleration sensors, see the respective manuals.



CAUTION

- Applying a voltage that exceeds the values indicated below to the accelerometer module may damage the input section.
Maximum Input Voltage
60 V (DC + ACpeak)(Overvoltage Category CAT I and CAT II)
- When connecting acceleration sensors, make sure the supply current (bias) to the sensors is OFF. Otherwise, damage to the internal circuitry of the acceleration sensors may result.

When Connecting Built-in Amplifier Type Acceleration Sensors

The WE7235 allows built-in amplifier type (low impedance) acceleration sensors to be directly connected. To connect built-in amplifier type acceleration sensors, use BNC cables. Use cables that are appropriate for the acceleration sensors being used. Connect acceleration sensors with the supply current (bias) to them turned OFF. After connection, turn ON the supply current to the acceleration sensors for making measurements.

When Connecting Charge Output Type Acceleration Sensors

Since the charge output type (high impedance) acceleration sensors do not have built-in amplifier circuit, they cannot be directly connected to the WE7235. Use either of the following two methods to connect the sensors.

- **Using the charge amplifier**

Connect the charge output type acceleration sensor to a charge amplifier using a highly isolated low-noise cable. The acceleration signal (charge signal) that has been converted to a voltage signal by the charge amplifier is input to the WE7235 using a normal coaxial cable. The WE7235 measures the signal in the voltage measurement mode. The measured data can be converted to acceleration values using the scale conversion function of the WE7235.

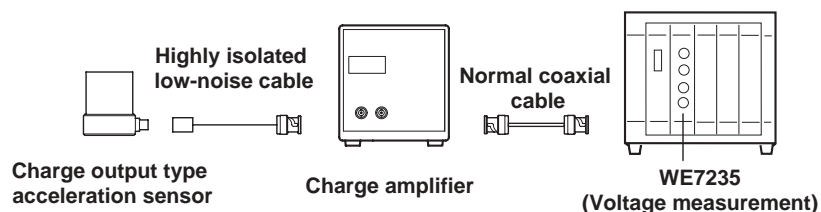

2.2 Connecting Acceleration Sensors

- **When using the charge converter**

Connect the charge output type acceleration sensor to a charge converter using a highly isolated low-noise cable. By driving the charge converter using a constant current from the WE7235, voltage signals similar to those of the built-in amplifier type acceleration sensor can be obtained. The WE7235 measures the signals in the acceleration measurement mode and supplies current (bias) to the charge converter. Set the input sensitivity of the WE7235 according to the charge converter gain and the sensitivity of the charge output type acceleration sensor.

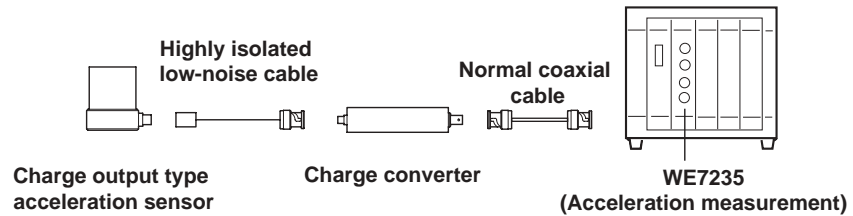

Note

The measurement input of the WE7235 is non-isolated. If isolation is required between the item being measured and the WE7235, use ground isolated acceleration sensors.

2.3 Connecting the Input Cable

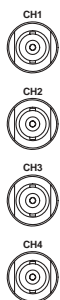

A BNC cable is used to input the signal to be measured. Connect the BNC cable to the input terminal (BNC terminal indicated as CH1 through CH4) on the front panel of the module. The input signal must conform to the following:

Number of inputs:	4
Input format:	Non-isolated, unbalanced
Input impedance:	Approx. 1 M Ω
Maximum input voltage:	± 60 V (DC+ACpeak) (Overvoltage Category CAT I and II)
Acceleration sensor:	Built-in amplifier type
Sensor supply current:	4 mA $\pm 10\%$
Sensor supply voltage:	Approx. 21 V



CAUTION

- Applying a voltage exceeding the maximum input voltage indicated above can damage the input section.

3.1 Troubleshooting

- If servicing is necessary, or if the analyzer is not operating correctly after performing the following corrective actions, contact your nearest YOKOGAWA dealer as listed on the back cover of this manual.
- To verify that the module is operating correctly, perform the self test as described on the next page.

Problem	Probable Cause/Corrective Action	Reference Page
Module does not operate.	Check to see that the module is installed correctly into the station. Also, install the module into another slot, and check whether it will operate there. If it operates in the other slot, the measuring station is likely to have malfunctioned. If the module is installed correctly and does not operate, the connector might be bad or the IC may have malfunctioned. In either case, contact your nearest YOKOGAWA dealer to have it repaired.	2-1, *
Waveform data cannot be acquired.	Check to see that the input cables are connected properly to the BNC terminals.	2-3 to 2-5
Noise enters the input signal.	If the signal line and the AC power supply line are close to each other, move them apart. Also make sure that the signal line is away from the noise source. Change to a shielded signal cable if you are not already using one. If the frequency of the input signal is known, remove the frequency region above the frequency component of the input signal by setting an input filter.	— 1-4
Measured values are not correct.	Check whether the ambient temperature and humidity are within the allowed ranges. If you did not allow a warm-up time of 30 minutes, try measuring again after the warm-up time has passed.	4-5
Trigger does not activate	Check whether the trigger setting is adequate for the input source in the trigger operation panel. If you are using the bus trigger signal, verify that the settings are correct in the trigger source/time base source/arming setting dialog box of the WE7000 Control Software.	1-2, 1-7 *
The waveform monitor does not appear.	Check to see that the waveform monitor ON/OFF button, located to the right of the Start button of the operation, is not set to OFF.	1-2

* See the WE7000 User's Manual (IM 707001-01E).

3.2 Acceleration Sensor Connection Test

The test performs diagnosis on shorted and opened conditions of the acceleration sensors including the cables.



CAUTION

Perform the connection test only when acceleration sensors are connected. A current of approximately 4 mA is supplied to the acceleration sensors during the test. Therefore, if a signal source other than an acceleration sensor is used during the test, the signal source may be damaged.

Executing the Test

Check that the acceleration sensor is connected to the terminal. The test cannot be performed while measurement is in progress.

1. Click **More Option** on the operation panel and select the **On** check box under **Connection Test**.

The displayed screen switches to the test mode.

Check that the check boxes for the channels being tested are selected

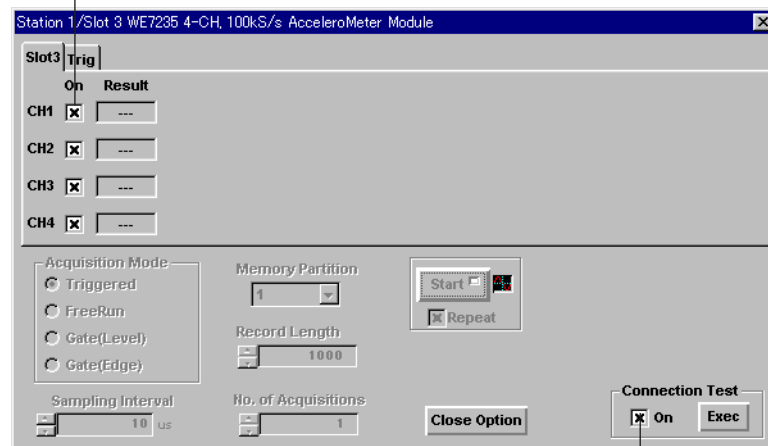

Select the check box

2. Check that the On check box for the channel to which the acceleration sensor being tested is connected is selected and click **Exec**. The test is executed.

Note

The ON/OFF setting of the channel performing the connection test cannot be copied using the copy-between-channels function.

Verifying Test Results

When the test is complete, the results of each channel are displayed in the Result box.

Slot1	Trig	On	Result	
CH1	<input checked="" type="checkbox"/>	<input checked="" type="checkbox"/>	OK	Normal
CH2	<input checked="" type="checkbox"/>	<input checked="" type="checkbox"/>	Open	Open
CH3	<input checked="" type="checkbox"/>	<input checked="" type="checkbox"/>	Short	Short
CH4	<input type="checkbox"/>	<input type="checkbox"/>	---	

The result of the connection test is determined by the input voltage measured when the supply current to the acceleration sensor is turned ON as follows:

Normal: Input voltage between 2 V and 20 V

Open: Input voltage greater than 20 V

Short: Input voltage less than 2 V

If you remove the On check box under Connection Test, the WE7235 returns to normal measurement.

3.3 Self Test

If you believe that the module is not operating correctly, perform the self test according to the following procedure with nothing connected to the input terminals of the module being tested and the external trigger input terminal/external I/O connector of the measuring station.

Executing Self Test

1. Select **Self Test** from the **System** menu of the WE7000 Control Software.

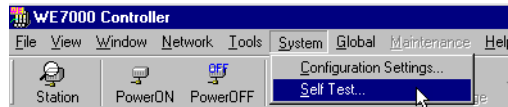

2. In the Self Test dialog box that appears, select the station name and enter the slot number corresponding to the module, and click **Execute**. "Executing..." is displayed in the Result display box.

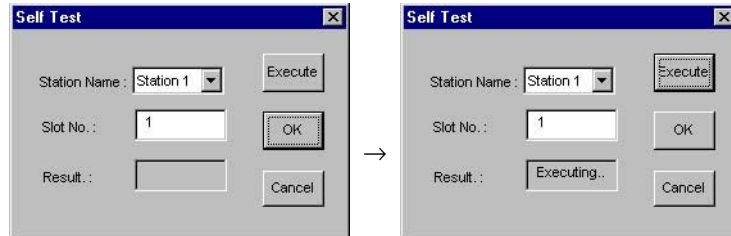

Verifying Test Results

If a value other than 0 is displayed in the Result display box of the Self Test dialog box, the module is probably malfunctioning. Please contact your nearest YOKOGAWA dealer as listed on the back cover of this manual for repairs.

3.4 Maintenance

Maintenance of Parts

There are no parts in this module that require periodic replacement.

Calibration

We recommend that you calibrate the measurement module once a year to assure its measurement accuracy.

Please contact your nearest YOKOGAWA dealer to have the module calibrated.

4.1 Performance Specifications

Number of Input Channels

4

Input Format

Non-isolated unbalanced input

Connector Type

BNC

Measurement Mode

Acceleration measurement and voltage measurement

Input Coupling

When measuring acceleration: AC only

When measuring voltage: DC and AC

A/D Resolution

Equivalent to 16 bits (including the sign)

Input Impedance

Approx. 1 M Ω

Allowable Signal Resistance

100 Ω or less

Frequency Characteristics (When Filter is OFF)

During DC coupling: DC to 40 kHz (–1.5 dB typical value^{*1})During AC coupling: 0.1 Hz to 40 kHz (–1.5 dB typical value^{*1})

Input Filter

Low-pass Filter

Characteristics: 4th order Butterworth (–24 dB/oct)Cut-off frequency: 40 Hz/100 Hz/400 Hz/1 kHz/4 kHz/10 kHz/40 kHz (3 dB, typical value^{*1})

Anti-Aliasing Filter

Characteristics: 8th order Cauer

Cut-off frequency: 20 Hz/40 Hz/80 Hz/200 Hz/400 Hz/800 Hz/2 kHz/4 kHz/8 kHz/20 kHz/40 kHz

Pass-band characteristics: 20 Hz to 20 kHz
 ± 1 dB at 5 to 100% of the cut-off frequency (typical value^{*1})
 40 kHz
 ± 1 dB at 5 to 50% of the cut-off frequency, –3 dB at 40 kHz (typical value^{*1})

Damping characteristics: 20 Hz
 –50 dB at 2.1 times the cut-off frequency (typical value^{*1})
 40 Hz to 40 kHz
 –80 dB at 2.1 times the cut-off frequency (typical value^{*1})

Acceleration Measurement

Applicable acceleration sensor: Built-in amplifier type
 Sensor supply current: OFF or 4 mA±10%
 Sensor supply voltage: OFF or approx. 21 VDC
 Sensitivity setting: Enter the acceleration sensor sensitivity on the operation screen (or using the WE Control API (sold separately, model: 707741))
 Measurement range: Measurement range automatically set according to the specified acceleration sensor sensitivity.
 Amplifier gain and accuracy (when filter is OFF with 1-kHz input under standard operation condition):

Gain	Accuracy	Temperature Coefficient (at 5 to 18°C and 28 to 40°C)
×1	±(0.5% of Full Scale ²)	±(0.01% of Full Scale ²)/°C
×2	±(0.5% of Full Scale ²)	±(0.01% of Full Scale ²)/°C
×5	±(0.5% of Full Scale ²)	±(0.01% of Full Scale ²)/°C
×10	±(0.5% of Full Scale ²)	±(0.02% of Full Scale ²)/°C
×20	±(0.5% of Full Scale ²)	±(0.02% of Full Scale ²)/°C
×50	±(0.5% of Full Scale ²)	±(0.03% of Full Scale ²)/°C
×100	±(0.5% of Full Scale ²)	±(0.05% of Full Scale ²)/°C

Voltage Measurement

Voltage range and DC accuracy (under standard operating condition):

Measurement Range	DC Accuracy	Temperature Coefficient (at 5 to 18°C and 28 to 40°C)
±50 mV	±(0.15% of rdg + 0.5 mV)	±(90 ppm + 20 μV)/°C
±100 mV	±(0.15% of rdg + 0.5 mV)	±(90 ppm + 25 μV)/°C
±250 mV	±(0.15% of rdg + 0.5 mV)	±(90 ppm + 40 μV)/°C
±500 mV	±(0.05% of rdg + 0.5 mV)	±(80 ppm + 40 μV)/°C
±1 V	±(0.05% of rdg + 0.7 mV)	±(80 ppm + 50 μV)/°C
±2.5 V	±(0.05% of rdg + 1.8 mV)	±(80 ppm + 100 μV)/°C
±5 V	±(0.05% of rdg + 3.5 mV)	±(80 ppm + 200 μV)/°C
±10 V	±(0.05% of rdg + 7 mV)	±(95ppm + 500 μV)/°C
±25 V	±(0.05% of rdg + 18 mV)	±(95 ppm + 1 mV)/°C
±50 V	±(0.05% of rdg + 35 mV)	±(95 ppm + 2 mV)/°C

Measurement range and AC accuracy (when filter is OFF with 1-kHz input under standard operation condition):

Measurement Range	AC Accuracy	Temperature Coefficient (at 5 to 18°C and 28 to 40°C)
±50 mV	±(0.5% of Full Scale ²)	±(0.05% of Full Scale ²)/°C
±100 mV	±(0.5% of Full Scale ²)	±(0.03% of Full Scale ²)/°C
±250 mV	±(0.5% of Full Scale ²)	±(0.02% of Full Scale ²)/°C
±500 mV	±(0.5% of Full Scale ²)	±(0.02% of Full Scale ²)/°C
±1 V	±(0.5% of Full Scale ²)	±(0.01% of Full Scale ²)/°C
±2.5 V	±(0.5% of Full Scale ²)	±(0.01% of Full Scale ²)/°C
±5 V	±(0.5% of Full Scale ²)	±(0.01% of Full Scale ²)/°C
±10 V	±(0.5% of Full Scale ²)	±(0.01% of Full Scale ²)/°C
±25 V	±(0.5% of Full Scale ²)	±(0.01% of Full Scale ²)/°C
±50 V	±(0.5% of Full Scale ²)	±(0.01% of Full Scale ²)/°C

Acquisition Mode

Trigger, free run, gate (level), gate (edge)

Memory Length of Acquisition Memory

4 Mwords

Memory Partition (partition possible only when trigger mode is selected)

Select from 1/2/4/8/16/32/64/128/256 partitions

Maximum Record Length

1 MWord/CH (when using 3CH/4CH), 2 MWords/CH (when using 2CH), and 4 MWords/CH (when using 1CH)

Time Base Source

Module's internal clock or the time base signal (CMNCLK) of the measuring station (WE bus), FFT time base (selectable only on the WE Control API (sold separately, model: 707741))

Maximum Sampling Rate

100 kS/s

Internal Time Base

10 μ s to 10 s (1- μ s steps)

FFT Time Base (selectable only on the WE Control API (sold separately, model: 707741))

51.2 kHz/20.48 kHz/10.24 kHz/5.12 kHz/2.048 kHz/1.024 kHz/512 Hz/204.8 Hz/102.4 Hz/51.2 Hz

Time Base Accuracy**When module's internal clock is selected**

Same as the reference clock accuracy of the measuring station (\pm 100 ppm for 707001/707002)

When FFT time base (selectable only on the WE Control API (sold separately, model: 707741)) is selected

\pm 50 ppm

Trigger Source

Input signal (including input signals from other digitizer modules that are linked) or the bus trigger signal (BUSTRG1/BUSTRG2) of the measuring station

Bus Trigger (BUSTRG1/BUSTRG2) Signal Output Source

The trigger detected from the input signal can be output

Trigger Level**Resolution**

When measuring acceleration

1% of the full-scale value (selectable range: +100% to -100%)

When measuring voltage

Measurement Range	Resolution
\pm 50 mV	0.1 mV
\pm 100 mV	1 mV
\pm 250 mV	1 mV
\pm 500 mV	1 mV
\pm 1 V	10 mV
\pm 2.5 V	10 mV
\pm 5 V	10 mV
\pm 10 V	100 mV
\pm 25 V	100 mV
\pm 50 V	100 mV

Hysteresis width

3% of (upper limit of range – lower limit of range) (typical value ^{*1})

Setting accuracy

3% of (upper limit of range – lower limit of range) (typical value ^{*1})

Trigger Type

Edge trigger, state trigger, and combination trigger (AND/OR of the input signal)

Amount of Pretrigger

Set in the range from 0 to (the record length – 2)

Sensor Connection Test Function

Checks the opened or shortened condition of the sensor (only when acceleration sensors are connected)

*1 The typical value is a representative or standard value. It is not a warranted value.

*2 The full scale value is the measurement range between 0 and the positive full scale value.

4.2 Default Values (Factory Default Settings)

On (measurement ON/OFF): On (CH1 to CH4)
Bias (supply voltage to the acceleration sensor ON/OFF): Off
Coupling (input coupling selection): AC
Unit (measurement range unit): m/s² (m/s²)
Range/Gain (measurement range/gain): ×1
Sensitivity (acceleration sensor sensitivity): 0.0 mV/Unit
Acquisition Mode: Triggered
Sampling Interval: 0.000010 s
Memory Partition: 1
Record Length: 1000
No. of Acquisitions: 1
AAF (anti-aliasing filter): Off (CH1 to CH4)
Filter (input filter): Off (CH1 to CH4)
Trig Type: Rise (CH1), Off (CH2 to CH4)
Trig Level: 0%
Trig Source: Internal
Trig Combination: OR
Pretrigger: 0 samples
Hold Off: 1000 samples
Time Base: Internal
CH Mode (Number of measurement channels): 4CH
Overlapped Acquisition: Off
Connection Test (acceleration sensor connection test): Off (CH1 to CH4)
Repeat (repetitive measurement): On

4.3 General Specifications

Safety Standards

Complies with CSA C22.2 No.1010.1 and EN61010-1, conforms to JIS C1010-1

- Overvoltage Category CAT I and II^{*1}
- Pollution Degree 1 and 2^{*2}

*1 Overvoltage Categories define transient overvoltage levels, including impulse withstand voltage levels.

Overvoltage Category I: Applies to equipment supplied with electricity from a circuit containing an overvoltage control device.

Overvoltage Category II: Applies to equipment supplied with electricity from fixed installations like a distribution board.

*2 Pollution Degree: Applies to the degree of adhesion of a solid, liquid, or gas which deteriorates withstand voltage or surface resistivity.

Pollution Degree 1: Applies to closed atmospheres (with no, or only dry, non-conductive pollution).

Pollution Degree 2: Applies to normal indoor atmospheres (with only non-conductive pollution).

EMC Standard

Emission

Complying Standard

EN55011 Group 1 Class A

This product is a Class A (for industrial environment) product. Operation of this product in a residential area may cause radio interference in which case the user is required to correct the interference.

Immunity

Complying Standard

EN61326 Industrial Environment

Testing Condition

Connect with the 3 m coaxial cable (3D2W).

Maximum Measuring Input Cable Length

30 m

Standard Operating Conditions

Ambient temperature: 23°C ± 5°C

Ambient humidity: 50 ± 10% RH

Supply voltage/frequency error: Within 1% of rating

After warm-up time has passed

Warm-up Time

At least 30 minutes

Maximum Allowable Input Voltage

±60 V (DC + AC peak)

Operating Conditions

Same as those of the measuring station

Storage Conditions

Temperature: -20°C to 60°C

Humidity: 20% to 80% RH (no condensation)

Power Consumption

12 VA (typical value at 100 V/50 Hz^{*3})

Weight

Approx. 0.8 kg

External Dimensions

Approx. 33(W) × 243(H) × 232(D) mm (projections excluded)

Number of Used Slots

1

Standard Accessories

User's Manual (this manual) (1)

*3 The typical value is a representative or standard value. It is not a warranted value.

4.4 External Dimensions

Unit: mm

WE7235 4-CH, 100 kS/s Accelerometer Module

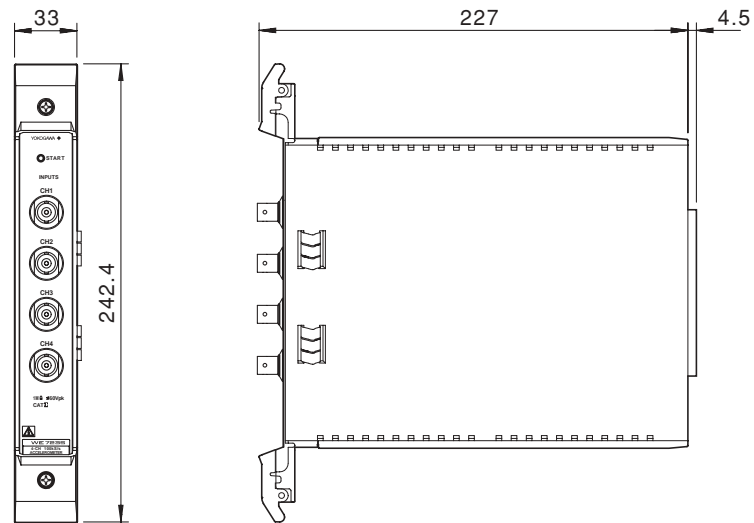

If not specified, the tolerance is $\pm 3\%$. However, in cases of less than 10 mm, the tolerance is ± 0.3 mm.

Index

Symbols

*.csv	1-8
*.wvf	1-8

A

AAF	1-4
AC	1-3
Acceleration Sensor Connection Test	3-2, 3-3
Acceleration Sensors	2-3
Acquisition Mode	1-4
AND trigger	1-7
Arming	1-10
Automatic Saving of Waveform Data	1-8

B

Bias	1-3
Both	1-7
BUSTRG	1-7

C

CH Mode	1-6
Combination	1-7
Connecting Acceleration Sensors	2-3
Connecting the Input Cable	2-5
Connection Test	3-2, 3-3
Contents of the Package	2
Controlling the Timing of the Start of the Measure	1-10
Converting Waveform Data	1-8
Coupling	1-3
Cyclic	1-8

D

DC	1-3
----------	-----

E

External Dimensions	4-6
---------------------------	-----

F

Fall	1-7
File Format Conversion	1-8
File number limit	1-8
Filter	1-4
Free Run	1-4
Front Panel	1-11

G

Gain	1-3
Gate (Edge)	1-4
Gate (Level)	1-4

H

High	1-7
Hold Off	1-7

I

Input Coupling	1-3
Input Filter	1-4
Input/Output of Bus Trigger Signals	1-9

Input/Output of Time Base Signals	1-9
Internal	1-7

L

Low	1-7
-----------	-----

M

Manual Trigger	1-7
Measurement Range	1-3
Measurement Unit	1-3
Memory Partition	1-5
MODEL	2

N

NO	2
No. of Acquisitions	1-5
Number of Measurement Channels	1-6

O

Off	1-7
Open	3-3
OR trigger	1-7

P

Pretrigger	1-7
------------------	-----

R

Range	1-3
Record Length	1-5
Repeat	1-4
Rise	1-7

S

Sampling Interval	1-5
Scaling	1-8
Self Test	3-4
Sensitivity	1-3
sensitivity of the acceleration sensor	1-3
Short	3-3
Source	1-7
Supply Current to the Acceleration Sensor	1-3
System Configuration	1-1

T

Time Base	1-6
Trig Level	1-7
Trig Type	1-7
Trigger Combination	1-7
Trigger Hold Off	1-7
Trigger Level	1-7
Trigger Source	1-7
Trigger Type	1-7
Triggered	1-4
Troubleshooting	3-1

U

Unit	1-3
------------	-----